

47566

AISC E&R Library



7305

1171



RR1171

7305

DESIGN OF STEEL TIED ARCH BRIDGES

AN ALTERNATIVE

By Dann H. Hall<sup>1</sup> and A. Richard Lawin<sup>1</sup>

For American Institute Of Steel Construction

July 1985

<sup>1</sup> Bridge Software Development International Ltd.  
Coopersburg, Pennsylvania

## TABLE OF CONTENTS

	Page
1.0 SUMMARY	1
1.1 Introduction	
1.2 Problem Statement	
1.3 Objective	
1.4 Approach	
1.5 Alternate Method	
2.0 INTRODUCTION	5
2.1 Present Practice	
2.2 Problems With Present Practice	
2.3 Proposed Alternate Method	
2.3.1 General	
2.3.2 Erection of the Arch Ribs	
2.3.3 Erection of Deck Units	
2.3.4 Advantages of Alternate Method	
3.0 DESIGN EXAMPLE BY ALTERNATE METHOD	17
3.1 General	
3.2 Design Considerations	
3.2.1 Live Load	
3.2.2 Dead Load	
3.2.3 Construction Loads	
3.2.4 Thermal Load	
3.2.5 Post Tensioning	
4.0 Analysis Using Finite Element Models	25
4.1 General	
4.2 Floor Beam	
4.3 Placement of Deck Units	
4.3.1 Arch Rib	
4.3.2 Hangers and Dead Load Tie Cable	
4.3.3 Precast Deck Units	
4.3.4 Bearings	
4.3.5 Procedure	
4.4 Integrated Model	
4.4.1 General	
4.4.2 Tie Beam	
4.4.3 Deck	
4.4.4 Floor Beams	
4.4.5 Procedure	

5.0 RESULTS

5.1 General

5.2 Floor Beam

5.3 Arch Ribs

5.3.1 General

5.3.2 Deck Unit Staging

5.3.3 Superimposed Dead Load

5.3.4 Temperature

5.3.5 Live Load

5.4 Hangers

5.4.1 General

5.4.2 Deck Unit Staging

5.4.3 Superimposed Dead Load

5.4.4 Temperature

5.4.5 Live Load

5.5 Dead Load Tie Cable and Reactions

5.5.1 General

5.5.2 Deck Unit Staging

5.5.3 Superimposed Dead Load

5.5.4 Temperature

5.5.5 Live Load

5.6 Tie Beams

5.6.1 General

5.6.2 Deck Unit Staging

5.6.3 Superimposed Dead Load

5.6.4 Temperature

5.6.5 Live Load

5.7 Deck

5.7.1 General

5.7.2 Deck Unit Staging

5.7.3 Superimposed Dead Load

5.7.4 Temperature

5.7.5 Live Load

5.8 Post Tensioning

5.8.1 General

5.8.2 Deck

5.8.3 Tie Beam

6.0 CONCLUSIONS

7.0 ACKNOWLEDGEMENTS

8.0 BIBLIOGRAPHY



LIST OF FIGURES

FIGURE	TITLE
2.1	Typical Tied Arch Bridge
2.2	Alternate Design - Deck and Tie Beam Unit
2.3A&B	Alternate Design - Arch Erection Schemes
2.4	Dead Load Tie Cable Anchorage
2.5	Erection Scheme for Deck Units
2.6	Deck Unit Layout
2.7	Arch Rib to Tie Beam Detail
3.1	Design Study Example
3.2	Design Study Arch Rib Cross Section
3.3	Design Study Deck Unit
3.4	Design Study Deck Cross Section
4.1	Floor Beam and Deck Model
4.2	Arch Rib and Staging Model
4.3A&B	Staging Sequence - Stage 2 - Stage 3
4.4	Integrated Model - Overview
4.5	Integrated Model - Details
5.1	Floor Beam Moment Envelope
5.2	Floor Beam Shear Envelope
5.3	Floor Beam Elevation
5.4	Floor Beam Influence Line
5.5	Accumulated Moments in Arch Rib Due to Deck Units
5.6	Accumulated Thrusts in Arch Rib Due to Deck Units

## LIST OF FIGURES (Continued)

FIGURE	TITLE
5.7	Stress Envelopes in Arch Rib Due to Deck Units
5.8	Dead Load Moments in Tie Beam
5.9	Location of Recorded Deck Stresses
5.10	Stresses in top of Deck Due to Superimposed Dead Load and Temperature - Design 1
5.11	Stresses in top of Deck Due to Superimposed Dead Load and Temperature - Design 2
5.12	Stresses in bottom of Deck Due to Superimposed Dead Load and Temperature - Design 2

LIST OF TABLES

TABLE	TITLE
3.1	Design Example Comparison
4.1	Model Explanation for Fig 5
5.1	Dead Load Moments in Arch Rib Due to Deck Units
5.2	Dead Load Thrusts in Arch Rib Due to Deck Units
5.3	Accumulated Moments in Arch Rib Due to Deck Units
5.4	Accumulated Thrusts in Arch Rib Due to Deck Units
5.5	Accumulated Stresses in Arch Rib Due to Deck Units
5.6	Summary of Arch Rib Moments
5.7	Summary of Arch Rib Thrusts
5.8	Factored Moments in Arch Rib
5.9	Factored Thrusts in Arch Rib
5.10	Summary of stresses in Arch Rib
5.11	Hanger Forces for Dead Load
5.12	Accumulated Forces in Hangers for Dead Load
5.13	Summary of Forces in Hangers
5.14	Reaction and Tie Cable Forces
5.15	Tie Beam Stresses at Hanger - Design 1
5.16	Tie Beam Stresses at Hanger - Design 2
5.17	Tie Beam Stresses Between Hangers - Design 2
5.18	Deck Stresses Top Line "A"



## LIST OF TABLES (Continued)

TABLE	TITLE
5.19	Deck Stresses Bottom Line "A"
5.20	Deck Stresses Top Line "B"
5.21	Deck Stresses Bottom Line "B"
5.22	Deck Stresses Top Line "C"
5.23	Deck Stresses Bottom Line "C"



## 1.0 Summary

### 1.1 Introduction

The tied arch bridge is composed of an arch rib on each side of the roadway, a tie beam associated with each arch rib which takes the thrust from the arches and a deck system supported by the tie beams. The deck system is most commonly composed of a concrete deck supported by longitudinal stringers in turn supported by transverse floor beams. Cable hangers connected between the arch ribs and the tie beams transfer the vertical loads from the tie beams to the arch ribs. Thus traffic passes between the arches at the lowest elevation of the arch ribs. Usually the arches are parabolic and braced overhead for stability.

Thrust from the arch ribs is resisted by the tie beams. The deck system is isolated from the tie beams to insure that tensile stresses are not introduced into the deck when the tension in the tie beam increases. This is done by segmenting the deck using stress relief joints. Lateral loads are carried by a bracing system which works with the tie beams. It is common to construct bracing at both top and bottom flange levels of the floor beams.

The arch ribs principally resist thrust; but bending components can be rather large. If the arch ribs are loaded evenly, the bending is minimized. Bending in the arch rib is reduced for a given concentrated load if stiffness of the tie beam is increased. This is most easily envisioned by thinking of the tie beam as a beam on elastic foundations, i.e. the hangers and arch ribs act as the foundations. The stiffer the tie beam, the more evenly distributed is the force in the hangers. This leads to more even loading of the arch ribs. Since the deck has been structurally isolated from the tie beams, neither it nor the longitudinal stringers contribute stiffness to the tie beams.

The structures are built from falsework. Spans range between 200 and 1000 feet for this type of bridge. They are used where single spans are required. If continuity from adjacent spans is available, tied arches are at a disadvantage compared to continuous trusses, cable stayed or even girder bridges.

## 1.2 Problem Statement

Tied arch bridges have become less popular because the tie beams are considered non-redundant. AASHTO Bridge Specifications define a non-redundant member as a tension member which, if it fails, is likely to lead to collapse of the structure. Although few, if any, tied arch bridges have actually failed, the tie girders have suffered cracks in one or two instances (Ref,2). It is clear that failure of such a member could be catastrophic. Further, the cost of tied arch bridges is high when compared to more modern bridges such as the cable stayed bridge and the segmental concrete box girder bridge.

There are several reason assigned to the high cost:

- o There are too many parts in tied arches;
- o Field labor is expensive;
- o The deck does not work with other components in the bridge;
- o The stress relief joints in the deck are expensive;
- o Non-redundant members are defined as fracture critical and must be designed and manufactured to more stringent requirements;
- o Falsework is often not needed on other types of bridges.

## 1.3 Objective

The objective of this study is to examine other possible means of constructing a tied arch bridge using modern techniques that would reduce or eliminate the undesirable non-redundant members, make the structure less expensive to construct; make more of the components work efficiently, eliminate as many of the pieces of the structure as possible and to reduce the amount of field labor, particularly, the elimination of falsework.

Several enabling technologies have been developed over the last decade that are believed to meet the above objectives. First was the advent of inexpensive high speed electronic computers which permit the examination of structural behavior in detail that was not economical in the past.



Second, the development of additives and improved techniques permit the routine manufacture of high strength concrete. There have been bridges built using concrete strengths specified as high as 8000 psi (Ref.3).

The emphasis of this study is on the use of the electronic computer technology by applying a bridge analysis and design computer program to the study. High strength concrete is employed in the design but the technology is not examined in detail.

#### 1.4 Approach

An alternate scheme for the construction of a tied arch bridge has been developed. A design study was then performed which was based on an existing design and the resulting design compared to the original. The analysis was performed using a series of computer programs called the BRIDGE-SYSTEM<sup>sm</sup> developed by Bridge Software Development International, Ltd. The computer generated model of the tied arch had to be modified by hand.

The BRIDGE-SYSTEM<sup>sm</sup> is based on the finite element method of analysis. It permits the designer to build, analyze and design large complex steel girder bridges efficiently.

#### 1.5 Alternate Method

In the proposed scheme, the arch ribs are erected first. They may be erected using a high-line or each half of the arch rib may be rotated into place from its bearing. During the erection, thrust must be taken by the abutments or by a temporary cable between the ends of the ribs.

After the arch ribs are erected, permanent cables are placed between the ends of arch ribs to carry dead load thrust. The cables must be supported by the hangers to prevent sagging and reduction of the effective modulus.

The deck and tie beam are precast concrete units. Each unit of the deck extends full width of the bridge. The deck is cast integrally with the tie beams. Each unit is equal in length to the hanger spacing. The deck is supported on composite steel transverse floor beams which frame into the tie beams. The units are floated under the bridge and lifted into place by hoists connected to the arch ribs.

When the units are in place and cast-in-place concrete completes the closure in the center, the units are post tensioned. Finally, the ends of the deck are cast-in-place and the deck is post tensioned to the ends of the arch ribs.

The concrete tie beams resist only thrust from the applied live loads and superimposed dead loads while the thrust from the dead load of the arch and deck system is resisted by the dead load tie cable. Thus the tie beam is non-redundant.

The deck is an integral unit after post tensioning and the joints within the span have been eliminated. This permits the deck to carry lateral loads to the abutments. There is no need for lateral bracing in cases where the deck is wide enough to resist these loads.

The entire structure may be erected without falsework. This should speed construction and greatly simplify scheduling construction and obtaining permits to obstruct channels.

A large amount of the field labor has been eliminated but the contractor still has the work of building the deck units. However, this work is off-site and not subject to weather and other undesirable features of field work.

Structural steel weight is reduced by approximately 2.6 million pounds. About 350,000 pounds of post tensioning steel is used. The dead load tie cables weigh about 300,000 pounds. Hangers remains unchanged.



## 2.0 INTRODUCTION

### 2.1 Present Practice

Steel tied arch bridges are used for moderate spans ranging from 200 to 1000 feet. Figure 2.1, which was produced by computer graphics, shows a typical tied arch bridge. The tied arch is most often used when a single span is needed or where the adjacent spans are so short that they would provide little benefit from continuity. They are considered by many to be aesthetically pleasing because functional lines are evident to even the most casual observer. The tied arch also provides maximum clearance, therefore, approaches may be reduced to a minimum.

The structure is composed of the arch rib, tie beams and a deck system. The arch rib usually has no hinges and tie beams are usually rigidly connected to the ends of the arch ribs. The rib itself is a welded box section although truss type arch ribs have been also used. The ribs are erected in sections by field bolting.

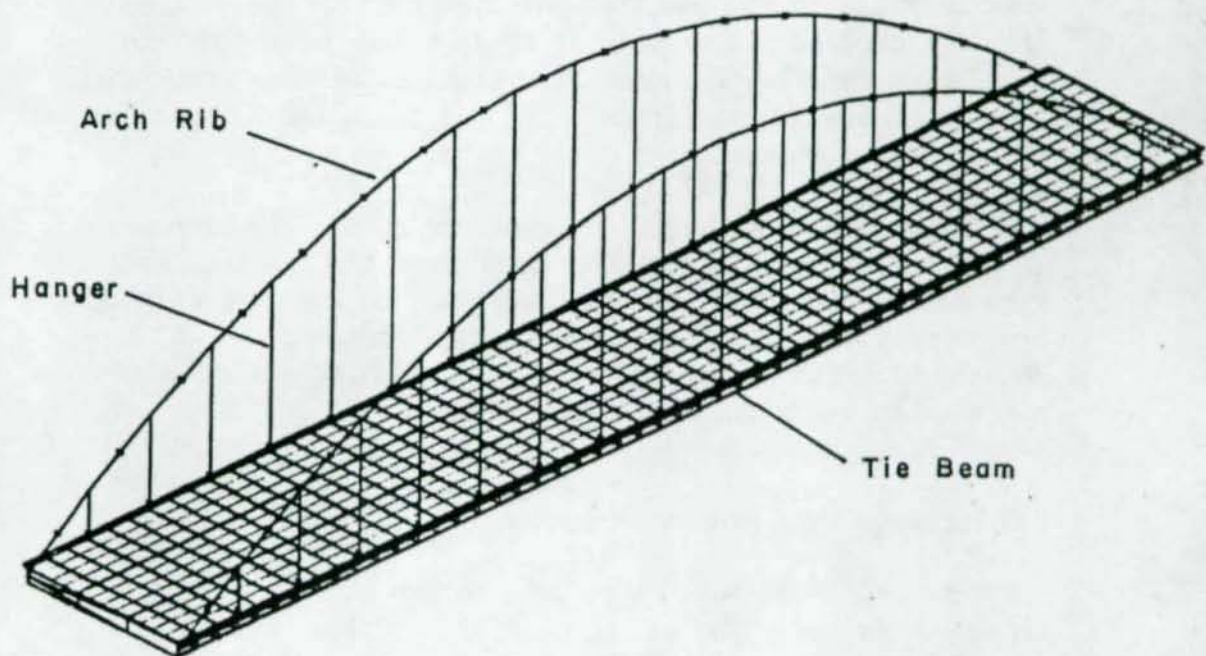

TYPICAL TIED ARCH BRIDGE

Fig 2.1



Thrust in the arch is resisted by a tie beam connecting the ends of the arch ribs. The tie beam is also erected in sections by field bolting and can either be an I- or box-shaped member. The two tie beam members are connected with a full moment connection to the arch rib and they are subjected to both tensile and flexural loads.

Hanger cables are used to suspend the tie beams from the arch ribs. It is through these hangers that the arch receives vertical loads. The hangers are commonly spaced at about 40 feet. The shape of the arch rib has been developed for uniform vertical loading; and a parabola can be shown to be the most efficient shape.

Tie beams connecting the ends of the arch ribs support a series of transverse floor beams. Floor beams are spaced so they fall at hanger locations to minimize bending in the tie beams. Floor beams frame into the tie beams at their top. Diagonal bracing resists transverse loads on the structure.

Floor beams support a series of longitudinal stringers. The stringers rest on either fixed or sliding bearings which isolate the floor beams from movement of the deck. Because the tie beam must be rigid in the longitudinal direction to resist tension, the deck must act separately if it is to be prevented from developing tensile stresses. Longitudinal strains occur from live loads and thermal loads. The joints in the deck are called stress relief joints.

The most common method of construction of tied arches is to place falsework in the span to support the tie beam and arch ribs during erection. The falsework may be kept in place during erection of the deck system and casting of the deck. This is done to minimize unsymmetrical loads during construction which might cause overstresses in the arch ribs.

## 2.2 Problems With Present Practice

Some engineers have expressed concern about the tied arch bridge described. The tie members are critical to the safety of the structure. If the tie member should fail for any reason, the structure would be likely to collapse. In the days of riveted construction, tie beams were composed of several thinner plates which provided redundancy. Presently, they are composed of three or four plates welded into a single member. If a crack should be initiated in the member, it is possible for it to propagate through the entire tie member.



The AASHTO Bridge Specifications (Ref.5) defines tension members that can cause collapse as Fracture Critical Members (FCMs). The Specification requires them to be designed to lower fatigue stresses. The material is subjected to more stringent toughness and inspection requirements during fabrication. These cautionary measures increase the cost of the bridge but the structure is still non-redundant. Some designers choose not to design non-redundant structures if they can be avoided.

Another undesirable characteristic is the many stress relief joints in the deck. These joints:

- o Present problems for maintenance;
- o Introduce a rough riding surface;
- o Add significantly to the initial cost.

The steel weight of the tied arch bridge is not significantly lower than other types of bridge construction and fabrication and erection costs are among the highest.

The need for falsework increases the cost of construction by not only adding cost directly but also by increasing the time to build the bridge. Falsework may provide an obstruction in shipping channels.

If the tied arch bridge is to remain a viable option, ways must be found to make it more competitive.

## 2.3 Proposed Alternate Method

### 2.3.1 General

The proposed method involves the use of precast deck units and a dead load tie member connecting the ends of the arch ribs acting as the tie beam for dead loads. It also assists the tie beam in carrying live and superimposed dead loads. The arch ribs remain similar in appearance to conventional tied arch designs. Construction differs significantly from normal in that the alternate structure may be erected without falsework. The deck is made of precast concrete units. These units include segments of the two tie beams cast integrally with the deck as shown in Figure 2.2. The units are post tensioned to overcome tensile stresses in them due to thrust from the arch ribs and local effects.



Roik and Hansel describe a similar bridge in Germany. The German structure utilized a post tensioned cast in place deck. The tie beams were steel (Ref.4).

Each precast deck unit is equal in length to the hanger spacing. The deck units are hoisted into place using the hangers and other stabilizing lines as shown in Figure 2.3. Transverse floor beams are spaced to permit the deck to span across the floor beams without longitudinal stringers. Three floor beams per precast unit is usually sufficient. Floor beams are composite with the deck for all dead and live loads. Steel has been used for the floor beams to minimize weight and to reduce forming. There are no diaphragms between floor beams. This reduces concern for secondary web bending which may cause fatigue problems. The deck is able to resist lateral loads since it is an integral element without stress relief joints. There should be no need for a lateral bracing system.

The deck units are to be match cast. A standard type of shear key on the interfaces will provide for shear transfer.

### 2.3.2 Erection of the Arch Ribs

The alternate method is best suited to sites where the span is over navigable water. A small cable is stretched across the span to take the thrust of the arch under its own weight. The Ernst Equation or some other method of determining equivalent stiffness for a sagging cable can be used to compute the cable modulus. It is necessary to prestress the cable to obtain a reasonable modulus.

The arch can be erected from each pier using a high-line as shown in Figure 2.3A. The center section of the arch can be erected from the high-line as shown. Alternatively, each half arch rib can be rotated into place and spliced at the center as shown in Figure 2.3B. At least one concrete arch has been successfully built in Germany using a similar technique (Ref.1). Wind bracing must be added between the arch ribs in either case prior to placing the deck units on the structure.

Once the arch ribs are erected, the initial moments and thrusts in the arch can be adjusted by tensioning the temporary cable. The temporary cables are replaced by permanent dead load tie cables.



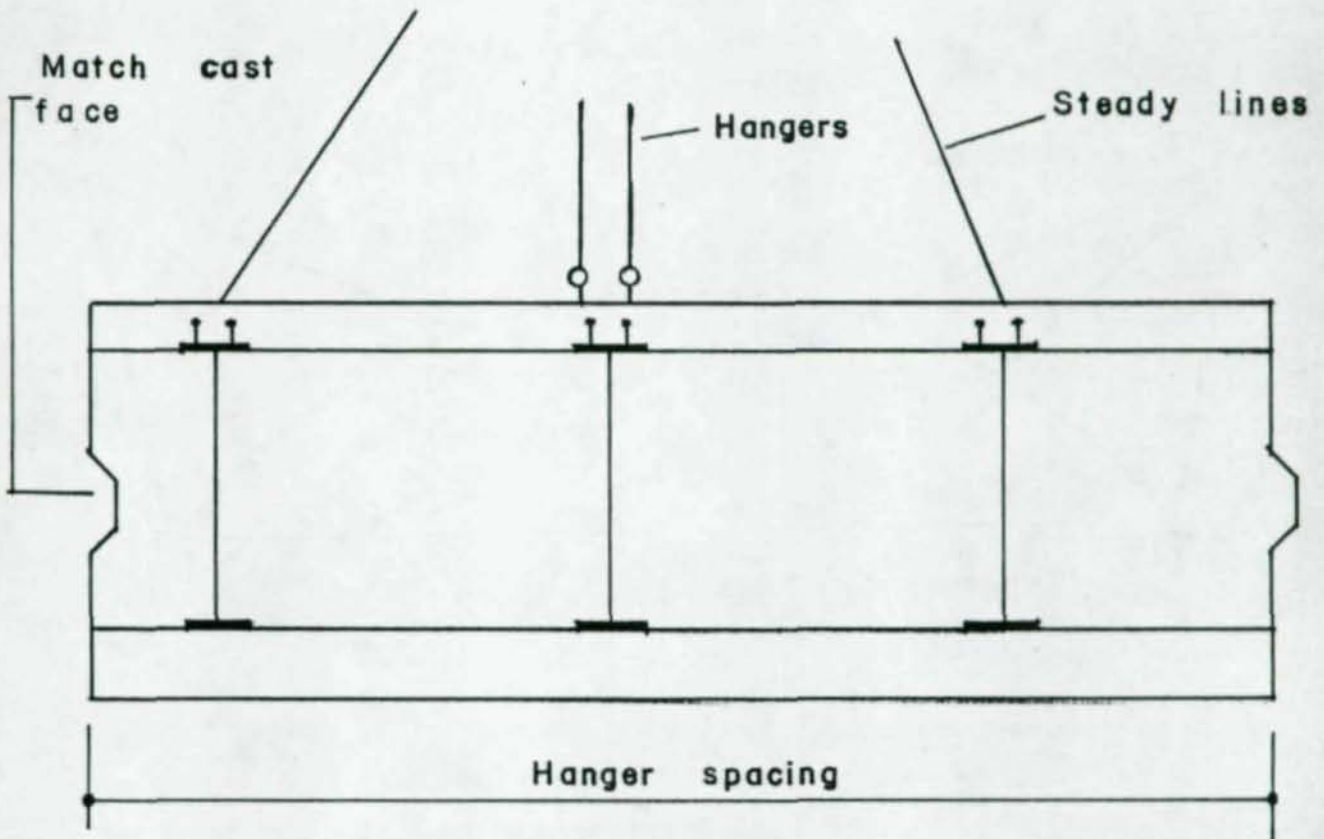
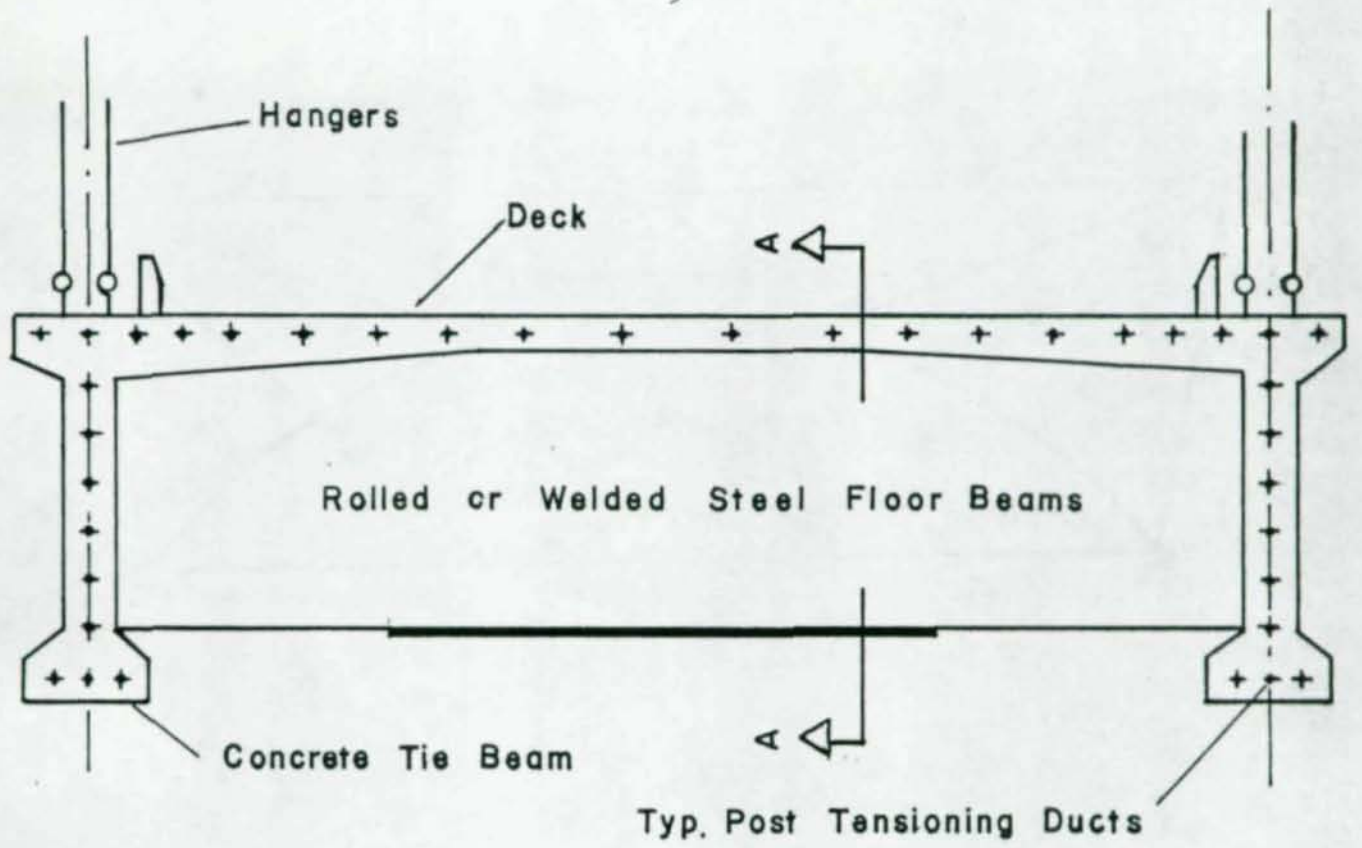

SECTION A-A  
DECK AND TIE BEAM UNIT

Fig 2.2

10

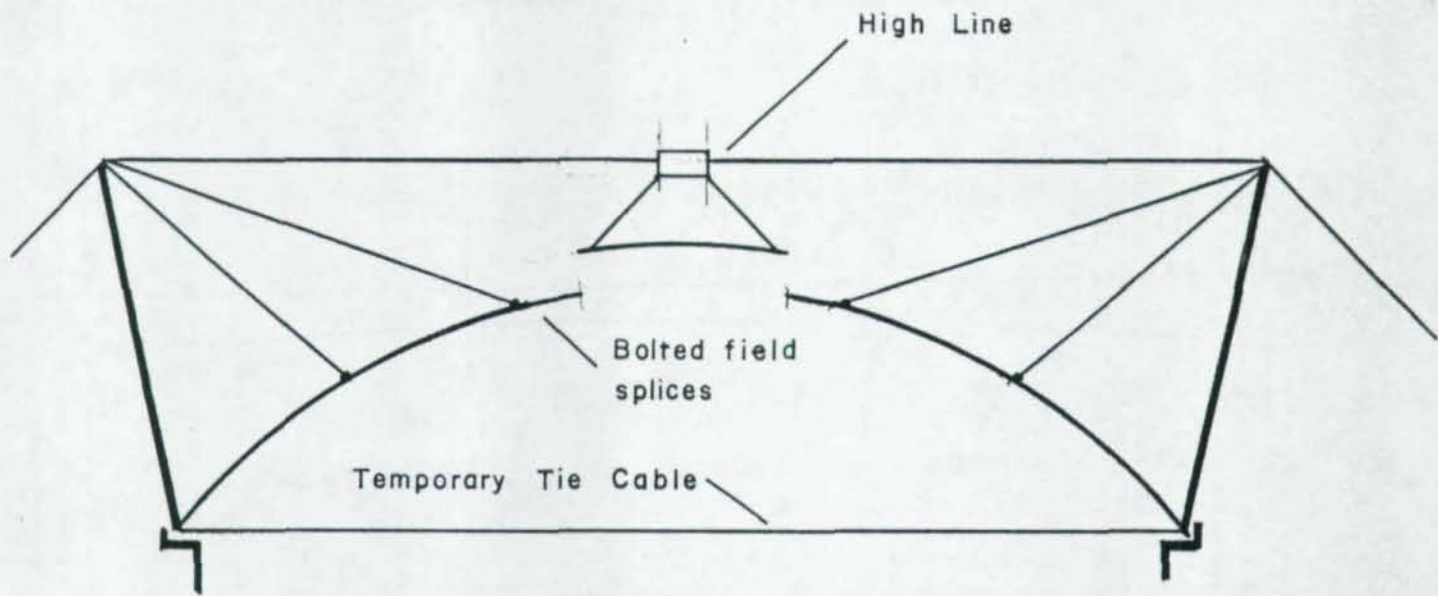
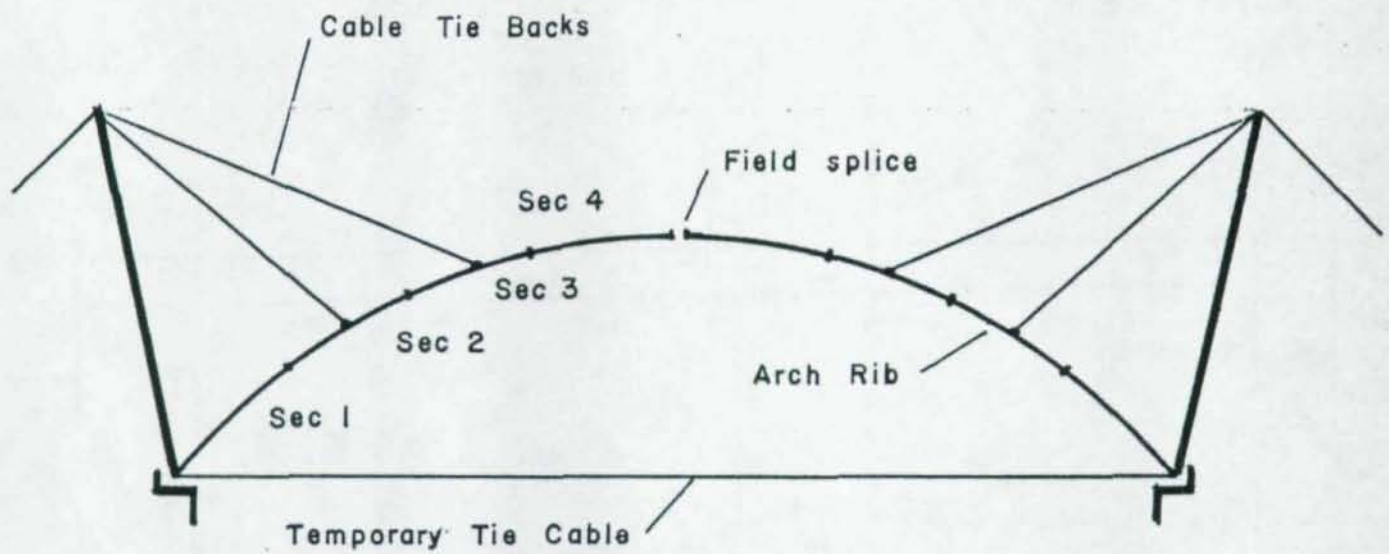

Fig 2.3A



ARCH ERECTION SCHEME

Fig 2,3B



These permanent cables are composed of parallel strands which are supported by the hanger cables and connected to the ends of the arch ribs. Intermediate support of this cable will insure that the modulus of the tie cable is fully effective. This cable is anchored to the arch as shown in Figure 2.4. The deck units are manufactured off-site and delivered under the arch ribs.

### 2.3.3 Erection of the Deck Units

Figure 2.5 shows the scheme for erection of the deck units. The deck units are precast off-site and barged to the bridge site where they are lifted into place by hoists attached to the arch ribs. During this process, the arch thrust is resisted by the dead load tie cable.

As the units are lifted into place, they are joined to the previous unit with minimal post tensioning. This is necessary to set the joints and to insure that wind loads during construction may be transferred to the ends of the span. When the first units are lifted into place, they are connected to the arch ribs by shear pins which insure that the units will be laterally stable. Units are lifted into place as shown in Figure 2.5. Note that lifting lines are connected at the outside floor beams in the units providing stability during erection. The hoists could be attached at different hanger positions on the arch to provide further stability. By using separate anchors for lifting and for permanent support, the cost of hangers is doubled. An option would be to use the lifting anchors as permanent hangers as shown on the right of Figure 2.5. Such a configuration would increase the hanger forces, particularly on the ends where the slope of the hangers becomes less vertical. Horizontal force must be considered in design of the post tensioning of the deck and tie beam units.

When the units are in place small donut type gaskets are inserted to seal the ducts at the joints. A few strands are installed to seat the joints and to insure that the units act as an integral unit during the erection process. The remaining post tensioning is installed when the center closure section of the deck, as shown in Figure 2.6, has been cast.

Post tensioning of the completed portion of the deck causes it to shorten free of restraint from the arch ribs. It may be desirable to let the deck creep at this time under the post tensioning load before it is connected to the arch ribs.

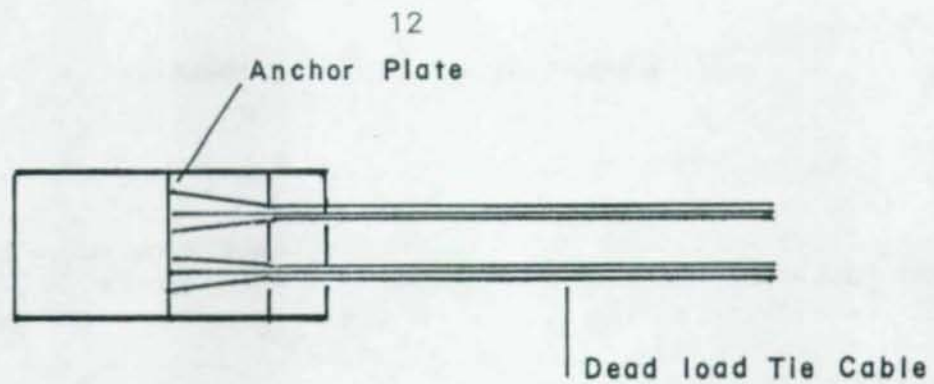

PLAN

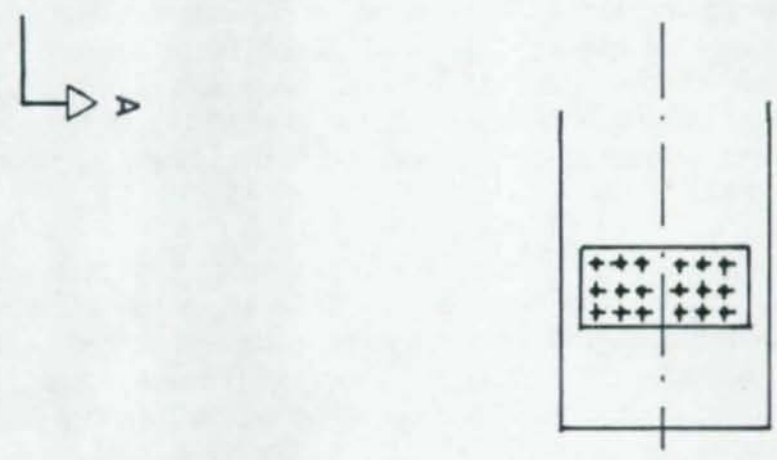
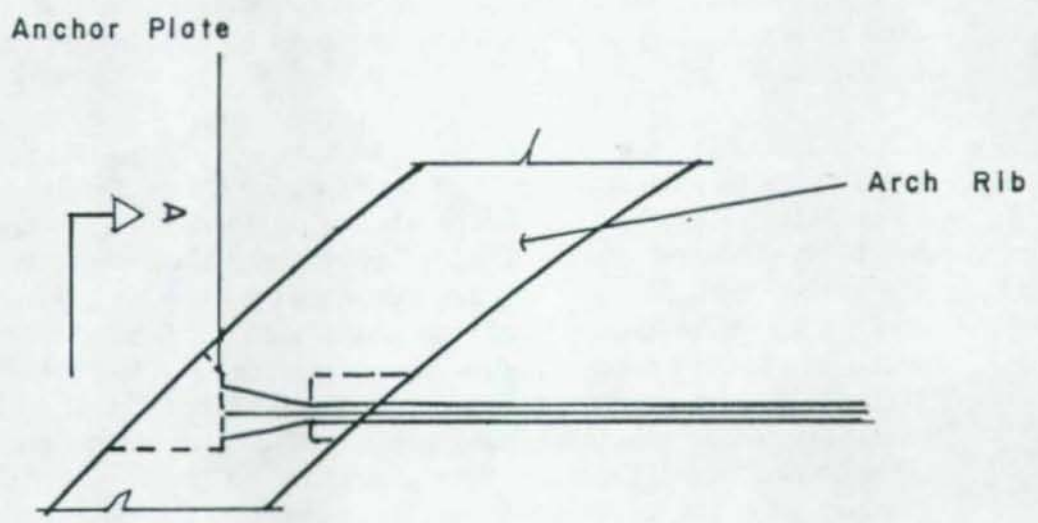

SECTION A-A

DEAD LOAD TIE CABLE ANCHORAGE

Fig 2.4



Alternative hanger arrangement

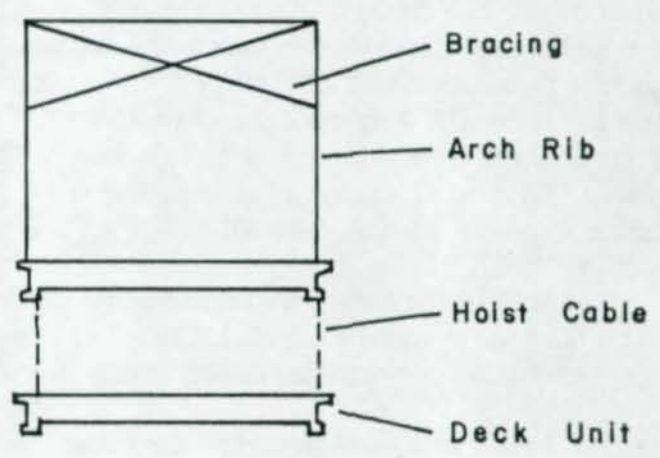
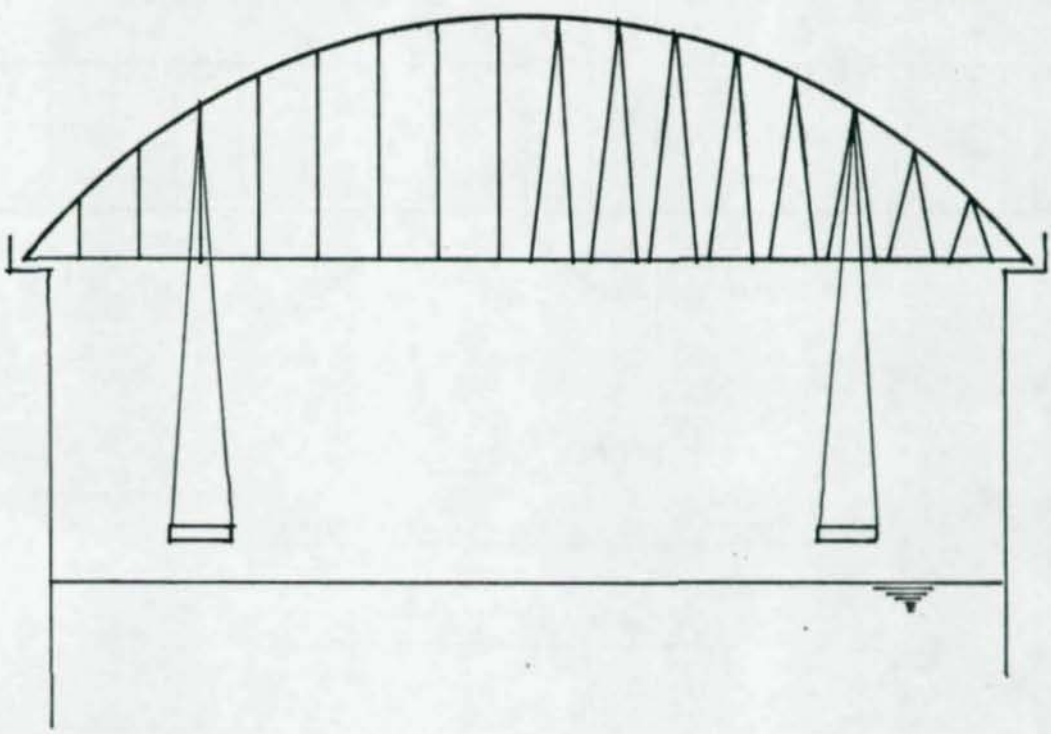

ERECTION SCHEME FOR DECK UNITS

Fig 2.5

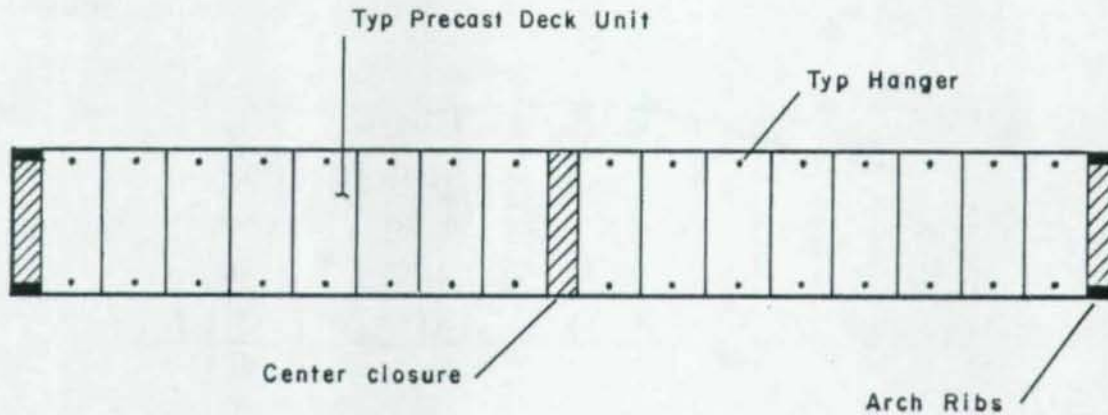

### DECK PLAN

(Shaded area to be cast-in-place)

### DECK UNIT LAYOUT

Fig 2.6

Next the deck is to be connected to the arch ribs, The end sections of the deck are now cast. The end sections are composed of portions of the deck between the arch ribs and portions of the tie beams between the end of the precast units and the arch ribs as shown in Figure 2.7. Final post tensioning is then done to form a full moment connection between the arch and the tie beams. This will cause a slight decrease in the post tensioning stress already in the deck.

To minimize weight, a concrete strength of 8000 psi is suggested where good aggregate is available. Some research indicates that high strength concrete tends to creep less.

Tie beams are designed for vertical bending induced by the floor beams framing into them. They must also resist bending induced by the arch ribs and hangers.

Since the deck is integral with the tie beams, it resists bending forces as part of the tie beam. Design of post tensioning in the deck must consider local bending stresses as well as overall bending and thrust stresses. The force from the arches and tie beams is transferred into the deck through shear. To accommodate shear, the deck must be thicker at the edges than it need be for local bending.

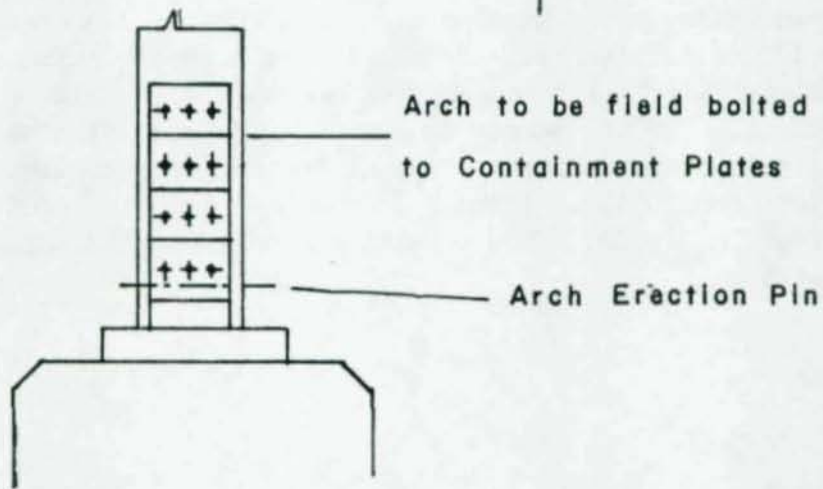
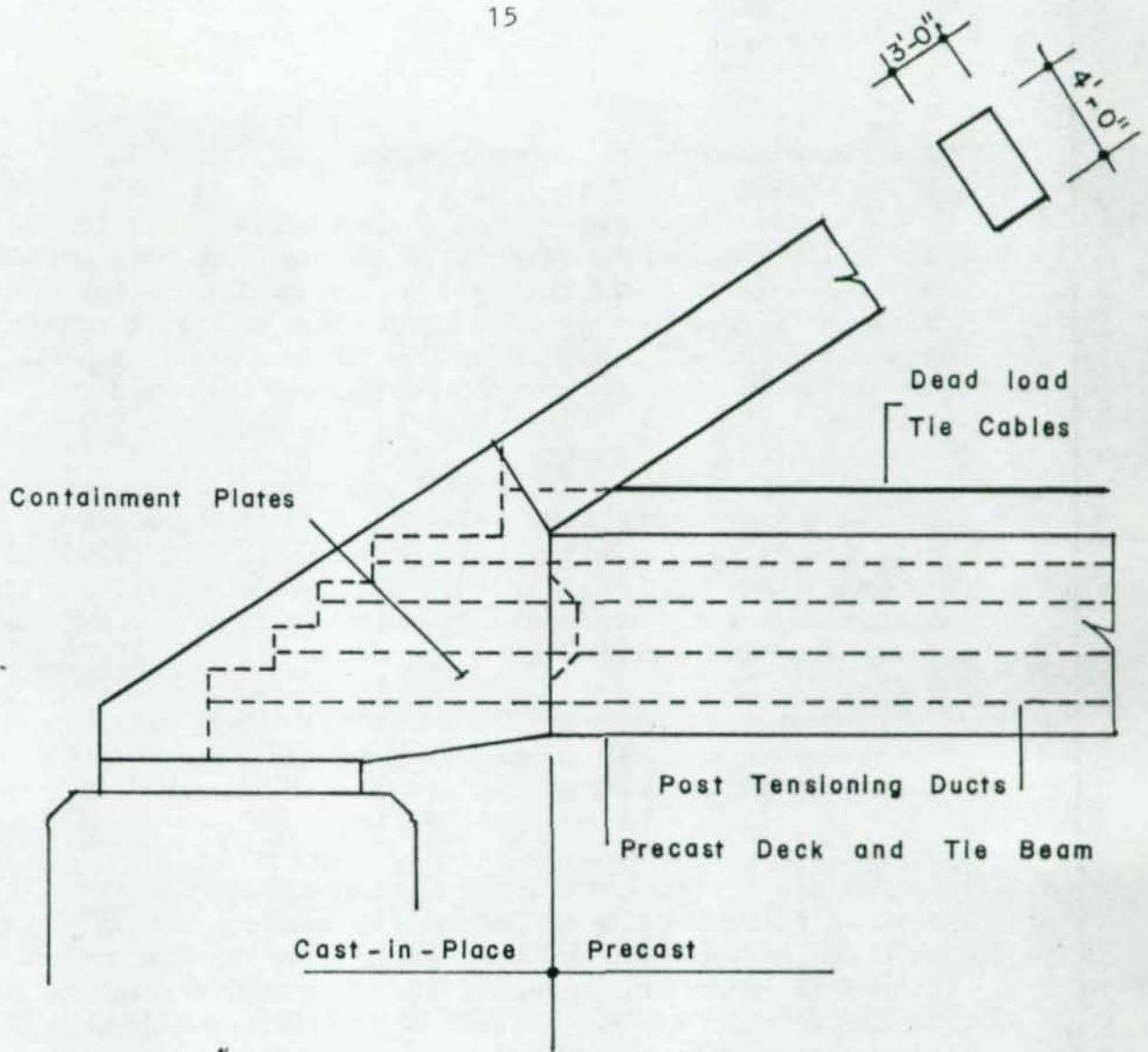

END ELEVATION

ARCH RIB TO TIE BEAM DETAIL

Fig 2.7



#### 2.3.4 Advantages of the Alternate Method

The proposed alternate method of construction eliminates the earlier outlined disadvantages of the tied arch. The problem of non-redundancy in the tie beams is eliminated by the multiple wires in the dead load tie cable and the post tensioning strand in the deck units. Instead of a large single element tie beam, multiple small wires are used to resist thrust from the arch ribs.

The costly stress relief joints in the deck are eliminated by post tensioning the deck. Falsework is also eliminated. This is made possible by the dead load tie cable which provides support during construction of the deck. Hopefully, construction will be much faster and navigation channels will be un-obstructed except for short periods.

Reduced steel weight should contribute to lower costs through both less base material and connecting material such as splice plates and bolts. Fewer splices also lead to reduced field labor.

The use of steel and concrete appears at first to be in reverse of good practice in that steel is used for the arch which is viewed as mainly a compression member while the deck concrete is used as part of the tie member which is viewed as mainly a tension member. However, the arch is also a flexural member subjected to rather large bending stresses. During construction, loads may induce net tensile stresses in the arch rib. The deck is used as part of the tie member which makes the overall design more efficient. The tie member is actually composed of high strength steel wire strand with respect to dead load applied prior to post tensioning. Tensile forces have been isolated from the flexural loads. This permits the use of efficient high strength strand.

### 3.0 DESIGN EXAMPLE BY ALTERNATE METHOD

#### 3.1 General

The best way to determine the feasibility of the proposed method is to perform a design study. The objective of this study is not to develop a complete design, but to examine the obvious problems in sufficient detail to determine feasibility of the method.

An existing design was selected as a basis for the design study. The original design was changed only where necessary to accommodate the alternate approach. This permitted some rather interesting comparisons of member sizes and design forces. AASHTO Load Factor provisions were used in the study.

Table 3.1 shows a comparison of the original and alternate designs. Figure 3.1 shows an isometric view of the design example.

TABLE 3.1 - DESIGN EXAMPLE COMPARISON

ITEM	ORIGINAL	ALTERNATE - DESIGN 2
SPAN	620.5 ft	Same
WIDTH BETWEEN ARCH RIBS	91.0 ft	Same
ARCH RIB HEIGHT	128.0 ft	Same
CONCRETE DECK	8" thick fc' = 4000 psi	15" to 9" thick fc' = 8000 psi
LONGITUDINAL STRINGERS	33" deep @ 9'-3" Spa (steel)	None
FLOOR BEAMS	9 ft deep steel Spacing = 36.5 ft	5 ft deep steel spacing = 12.17 ft
DIAGONAL BRACING	Box sections steel top and bottom of floor beams	None
JOINTS IN DECK	Every 36.5 ft	620.5 ft
HANGER SPACING	36.5 ft	Same
TIE BEAM	11 ft deep (steel)	9 ft deep (concrete)



The arch ribs rises 128 feet above the deck. They are unchanged from the original design except that the plates are kept at a constant thickness across the entire span. In the original design, the plates are thinner in the center of the span. The cross section of the arch ribs is shown in Figure 3.2.

Figure 3.3 shows the deck units. The floor system in the original design utilizes floor beams at 36.5 feet which supports stringers spaced at 8'-0" and an 8.0 inch thick concrete cast-in-place deck. There are lateral bracing members in planes of both top and bottom flanges of the floor beams. The alternate design utilizes floor beams spaced at 12'-2" with no longitudinal stringers or lateral bracing system. External to the deck units, the dead load tie cables take thrust from the arch ribs due to the dead load of the deck units.

The deck is 9.0" thick in the center 50 feet in the alternate design. This thickness is sufficient to span between the floor beams. At the tie beams, the deck is 1'-3" thick to provide adequate shear strength for transfer of shear from the tie beam to the deck.

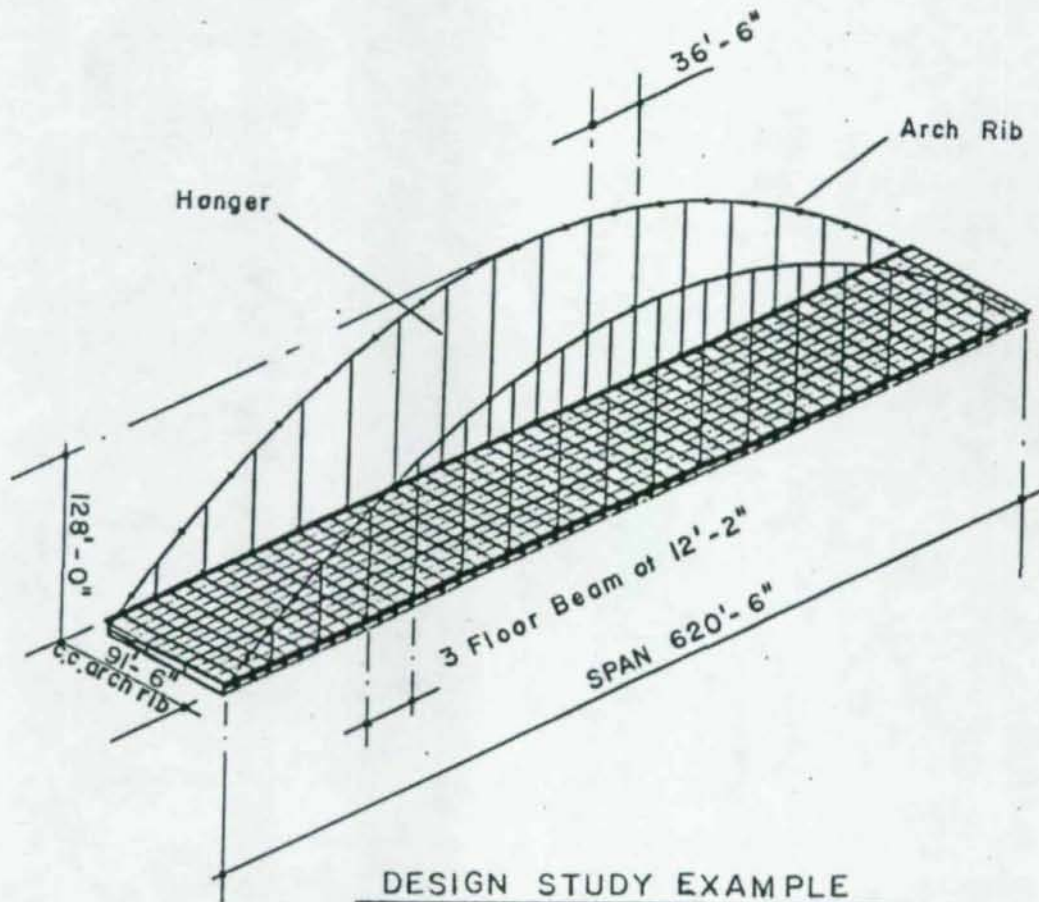

Fig 3.1

### 3.2 Design Considerations

#### 3.2.1 Live Load

AASHTO Bridge Specifications are applicable to bridges with spans up to 500 feet. Although this example exceeds 500 feet, no modification was made to the loading since the original designers apparently made no such modification. The original design was based on HS20 plus Interstate. The same live loading was used in the design study.

AASHTO specifies when four or more traffic lanes are loaded to obtain the maximum load, the resultant forces are to be reduced to 0.75 times the computed value to account for the low probability of the maximum load occurring simultaneously in all lanes. This factor is applicable to nearly all live loads reported in the study.

Lane load controls most longitudinal members. Floor beams are controlled by Interstate loading for strength, HS20 vehicle load controlled fatigue. Hangers are controlled by the HS20 lane load. Allowable fatigue stresses are based on Roadway Case I and redundant condition. Interstate loading is not considered for fatigue.

Figure 3.4 shows the deck cross section. Although there is a barrier in the center of the deck, it is ignored when examining lane positioning for critical conditions because the barrier could be removed at some future date.

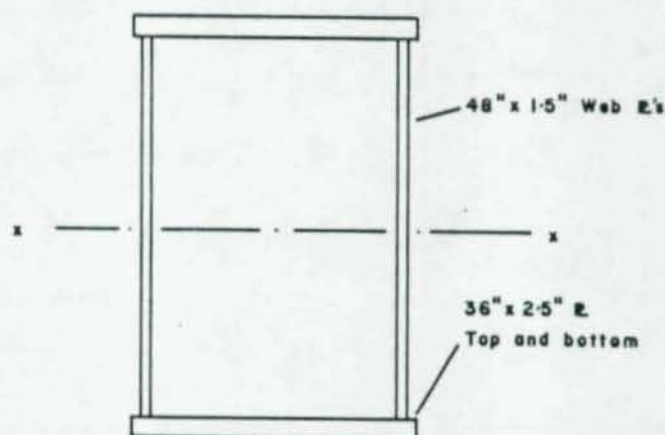

Area = 324 in<sup>2</sup>      I<sub>xx</sub> = 131000 in<sup>4</sup>

ARCH RIB CROSS SECTION

Fig 3,2



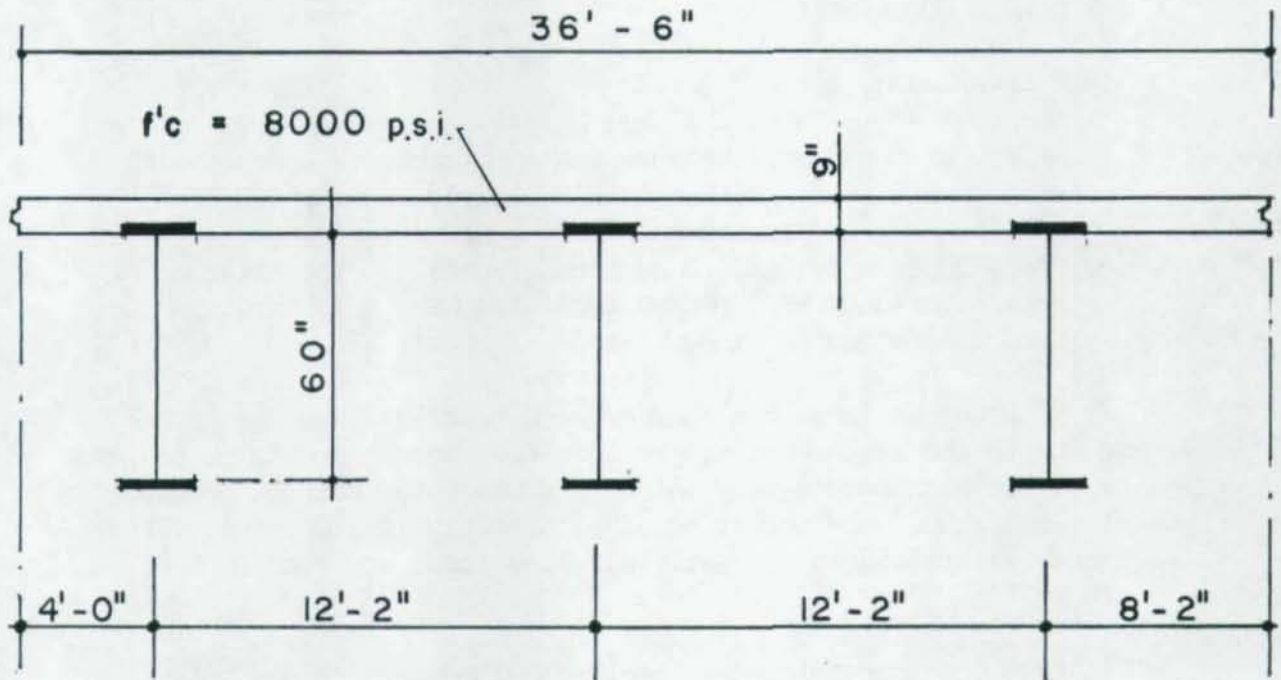

SECTION A-A

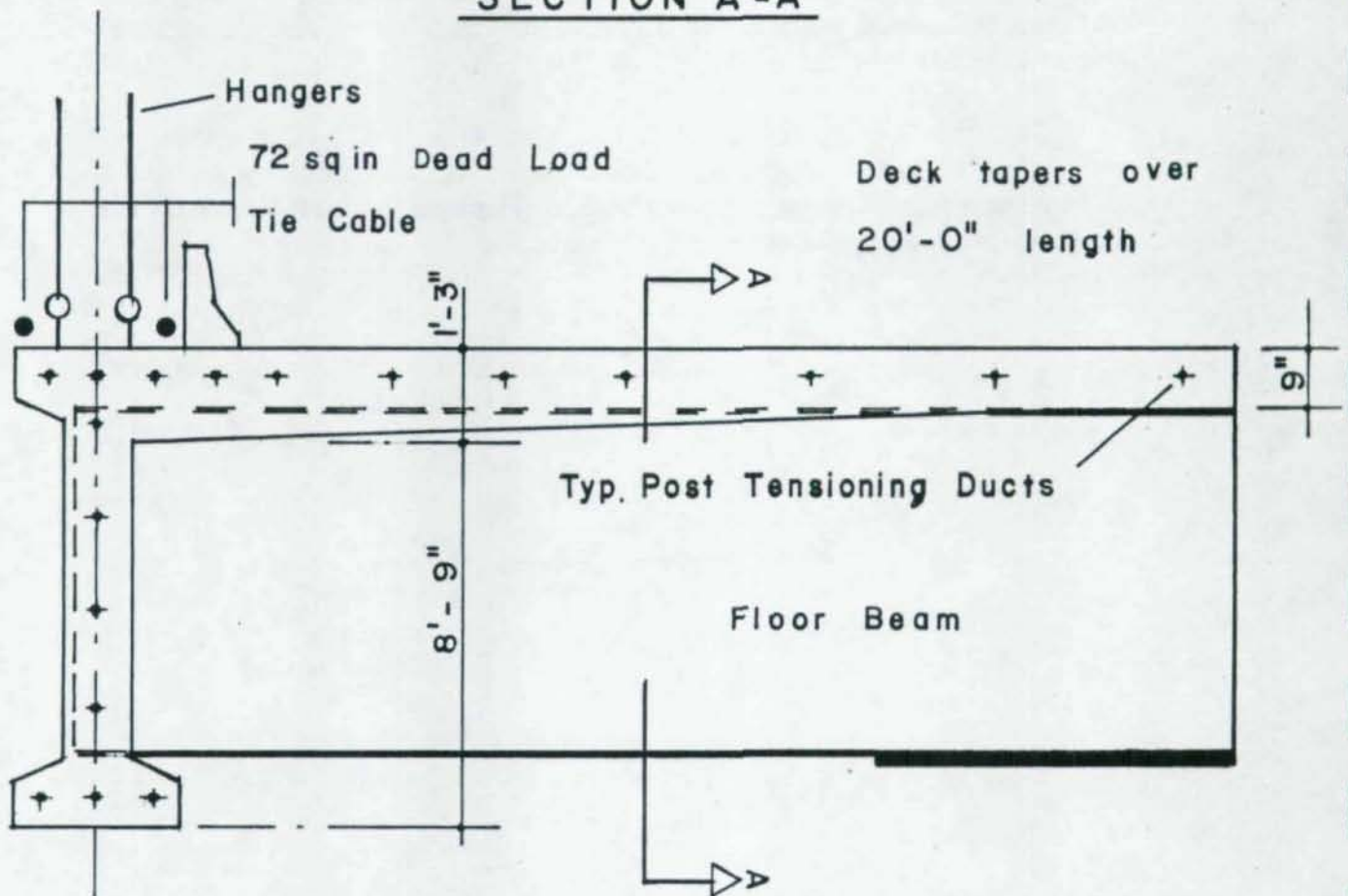

DESIGN STUDY DECK UNIT

Fig 3.3

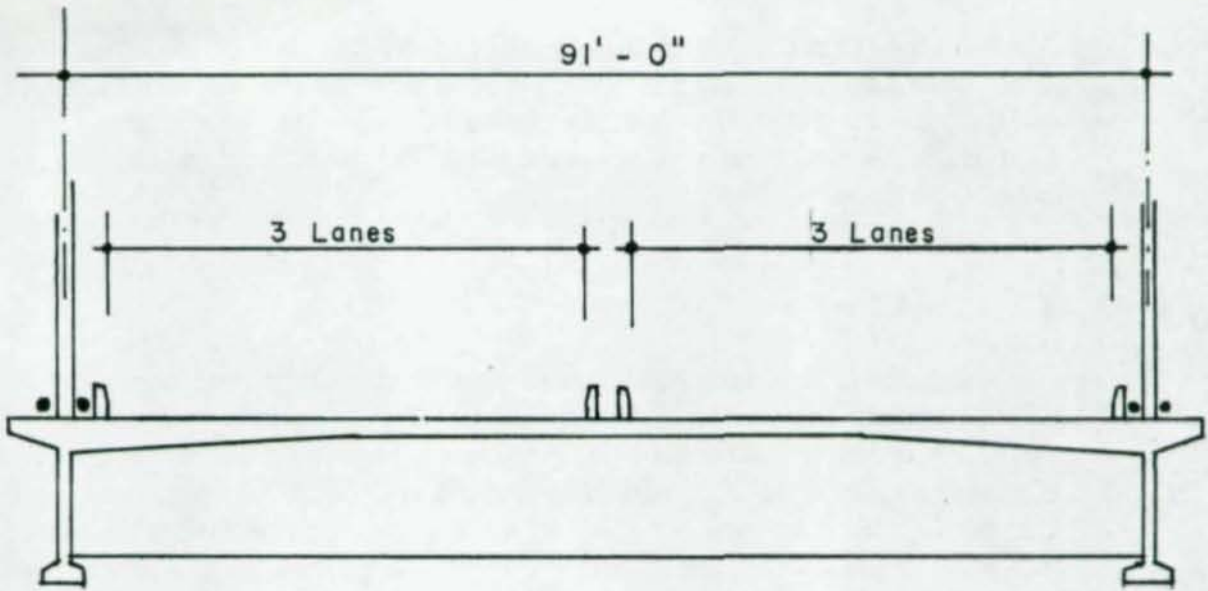

DESIGN EXAMPLE

CROSS SECTION OF DECK UNIT

Fig 3.4



Six 12-foot traffic lanes are permitted on the structure. The live load is six feet wide and may move within its 12 foot lane as long as it stays two feet from the edge of its lane. Each 12 foot lane may be moved transversely, but must not override an adjacent lane.

### 3.2.2 Dead Load

Dead loads are computed based on a unit weight for concrete of 150 pounds per cubic foot and steel of 490 pounds per cubic foot. A wearing surface of 30 pounds per square foot of riding surface is added to the superimposed dead load. Parapets and the center barrier are considered in the superimposed dead load. The weight of the parapets and barrier are placed on the structure as a series of concentrated loads at the nodes over floor beams. The barrier and parapets could be precast with the units. In that case they would be considered part of the dead load of the deck units.

### 3.2.3 Construction Loads

The feasibility of any large bridge is dependent on its constructability. Although a complete examination of construction stresses is beyond the scope of the study, it is extended to evaluate, in an elementary manner, construction of the deck units.

The stresses in the arch ribs during their erection are not reported. However, computations were made to determine that erection stresses in the ribs were not critical with practical length stiff legs and tie backs. Construction stresses in the arch ribs just prior to placement of the deck units must be known so they can be added to stresses from subsequent loads. These stresses are given.

Placement of the deck units is examined in some detail. Pairs of deck units are assumed placed simultaneously on the structure. Each deck unit is composed of three steel floor beams and their portion of deck slab and two tie beam segments.

At this point, the dead load tie cable is the only member resisting thrust of the arch ribs. The deck units are connected to the ends of the span by shear pins to resist lateral loads and insure that the deck does not sway. Each unit is sufficiently post tensioned to the prior unit to set the joint and resist wind loads during erection.



When all units have been erected and the center closure portion has been cast, the deck units are finally post tensioned. Portions of deck and tie beams subsequently cast at the ends of the bridge. Final post tensioning of these portions to the precast units insures a full moment connection to the arch ribs and integral action by the entire deck. The final post tensioning tends to unload the stress in the main portion of the deck. Post tensioning of one end to the arch will simply translate the deck slightly toward that end. However, post tensioning of the last end will be resisted by the arch rib. Tensioning will tend to unload the tie cable and increase thrust in the arch. This behavior must be considered when designing the post tensioning.

#### 3.2.4 Thermal Loads

The possibility exists that solar energy could heat up the arch ribs, hangers and tie cables more quickly than the massive deck and tie beams. If this happens, the post tensioning stress will be reduced. We have estimated a temperature difference to enable us to consider this effect in the design of the post tensioning. Conversely, the arch may cool more quickly than the concrete. This should also be considered in an actual design but is not considered in this study. Additional deck stresses are induced due to the increased thrust in the arch ribs. The effect on the arch ribs is also examined. The results of the thermal analysis are designated as "Temperature".

#### 3.2.5 Post Tensioning

The amount of post tensioning required in the deck and tie beams is determined by the amount required to overcome the largest tension stress in the concrete. Tensioning prior to losses is limited by the compressive strength of the concrete. Two cases are examined in this study:

$$\text{CASE I } 1.3(D + 5/3(L + I));$$

$$\text{CASE II } 1.3(D + T + (L + I)).$$

Allowable stresses for CASE II are increased by 25 percent.

Maximum tension and compression are determined for each condition. It is assumed that post tensioning in the deck is at the center of gravity of the deck for overall effects and for simplicity at one-sixth the thickness of the deck away from the center for local bending.



Losses due to creep and shrinkage as well as anchorage and friction are considered in the design study. The age of the units, relative humidity and several other factors are not considered but should be considered in a detailed design.

Preliminary post tensioning of the precast units is performed immediately after they are lifted into place. The majority of post tensioning is performed after all of the units are connected and the center closure section is cast. The moment connection between the deck and the arch ribs is made by post tensioning the deck to the cast in-place end sections. Final tensioning tends to unload the tensioning in the other and is accounted for by over tensioning the precast units.

## 4.0 ANALYSIS USING FINITE ELEMENT MODELS

### 4.1 General

The majority of the analysis in the design study is performed using the finite element method. FESAP, the finite element computer program that is utilized in the study, is licensed to BSDI by Babcock & Wilcox.

BSDI has developed a number of interactive computer programs that are utilized to build the finite element model and a similar number of programs that process the analysis produced by FESAP. The results of the analysis appear to the user in the form of moments and shears rather than as raw finite element stresses. There is also a computer program which places a specified live load on an influence surface that has been developed from the FESAP analysis. In the course of the analysis, hundreds of influence surfaces are subjected to the loader. The computer programs are part of the BRIDGE-SYSTEMS<sup>sm</sup> developed for girder bridges but modified to analyze the tied arch in this study.

The model built to evaluate the placement of deck units is a two-dimensional (2D) model. A 3D model is used to analyze the floor beams. Finally, a fully integrated 3D model is used to analyze the entire structure for superimposed dead load, thermal and live load.

The integrated 3D model has 3490 elements and an equal number of nodes. The minimized band width is 485. The integrated structure has been run on a VAX 11/780 computer. The interactive programs are run on a Victor 9000 microcomputer.

### 4.2 Floor Beam

The floor beams are designed first so that they can be properly modeled in the integrated model and so the proper deck thickness is known. This permits the weight to be more closely estimated when examining staging of the deck units.

The floor beams are modeled by considering entire deck unit of three floor beams with its corresponding width of deck, 36'-6". Design of floor beams was predicated on simple span behavior.

The webs of the girders are modeled using a single plate element over the girder depth. This assumption requires a further assumption that shear is constant over the girder depth. The top and bottom flanges are modeled with beam elements.



Thirteen nodes are evenly spaced over the 91.5 foot width. The deck was modeled using eight-node solid elements. Six elements were used across the 36'-6" deck section. The deck is connected to the steel girder elements with very rigid beam elements in the vertical orientation. This insures full composite action. The model is shown in Figure 4.1. The modulus of elasticity for the concrete and steel were input based on AASHTO.

The concrete modulus is adjusted by a factor of three (3.0) to account for creep and shrinkage when analyzing for dead load. The analysis is performed by hand since the BRIDGE-SYSTEMS<sup>sm</sup> loader works only in the longitudinal direction. The design is performed in interactive design programs using the properties described. The design program permits the user to modify plate sizes and check stresses using the AASHTO Load Factor Design criteria.

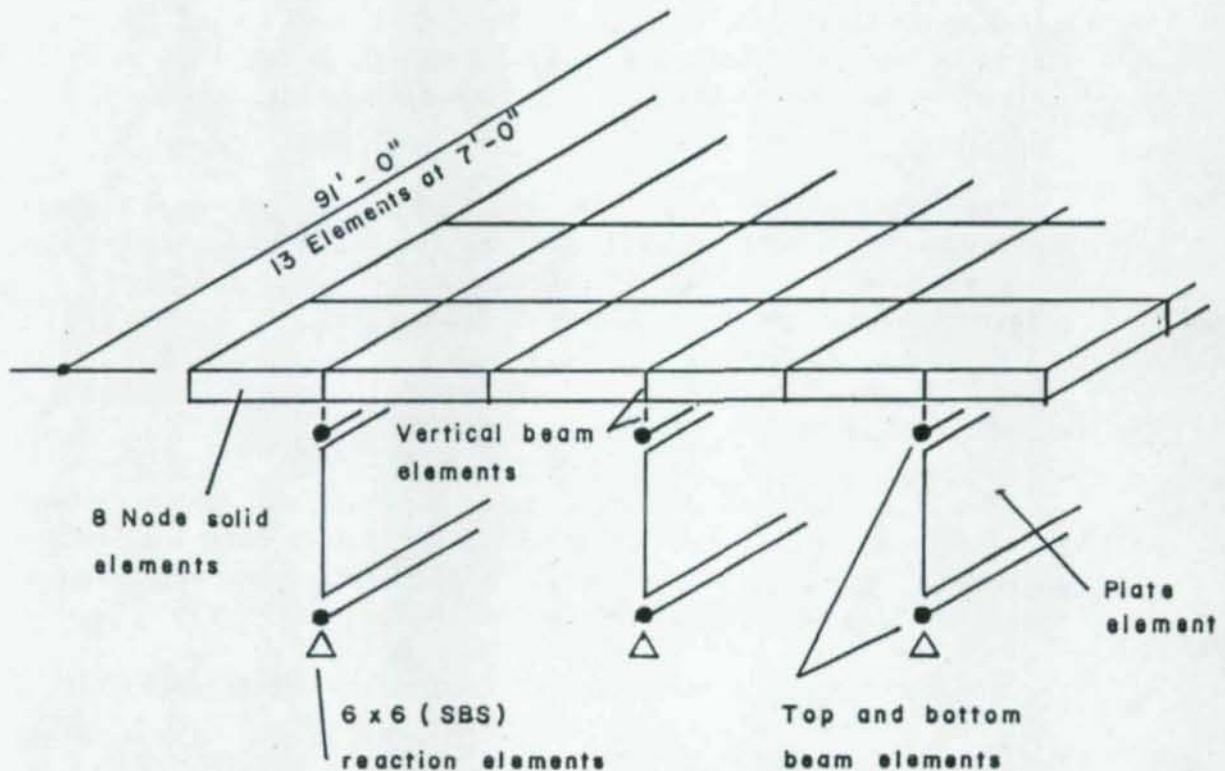

FLOOR BEAM AND DECK MODEL

Fig 4.1

### 4.3 Placement of Deck Units

#### 4.3.1 Arch Rib

Placement of the deck units on the arch structure is examined using a 2D finite element model. The arch ribs, dead load tie cable and tie beam on one side of the bridge were modeled. The model is shown in Figure 4.2. Since the arch rib is actually modeled using 3D elements, a third reaction at the top of the rib and preventing lateral translation is required.

A series of beam elements are used to build the arch. The coordinates are computed using the parabolic equation:

$$y = 0.001288(616.910x-x^2).$$

The elements for the arch rib extend between hanger locations along the parabolic shape of the arch. Figure 3.2 shows the box cross section and properties of the arch rib. In the design study, the plate thicknesses are held constant over the entire span. There are 34 elements in each arch rib. All elements are straight.

#### 4.3.2 Hangers and Dead Load Tie Cable

The cable members in the structure are modeled using spar elements. The hangers are the same as in the original design, Area = 6.67 in<sup>2</sup>. The area of the dead load tie cable is 72 in<sup>2</sup>. The modulus in the cable elements is 28000 ksi. The dead load tie cable is connected to the nodes at the ends of the arch rib.

#### 4.3.3 Precast Deck Units

The precast units are modeled as beam elements. The stiffness of the beam element is computed as the combine stiffness of half of the entire deck unit. Young's modulus for live load is used for the concrete. Although the entire deck is not effective due to shear lag, it is believed that the error introduced by this assumption is small. The moment of inertia about the horizontal axis of the tie beam used is 500 ft<sup>4</sup>. The area of the tie beam used is 55 ft<sup>2</sup>.

Tie beams are not connected to the arch ribs at this time. Three beam elements are used to represent the tie beam and deck between each hanger. Each node in the tie beam represents the location where a floor beam is connected. The weight of each deck unit is applied as three (3) concentrated loads at the nodes of the units being placed. This arrangement is shown in Fig 4.2



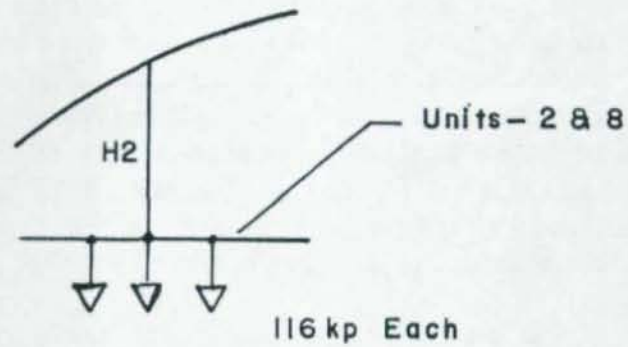
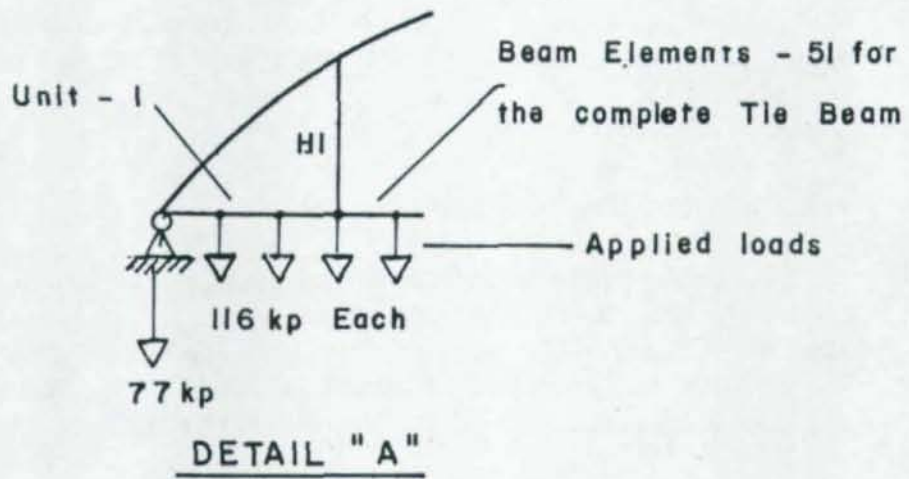
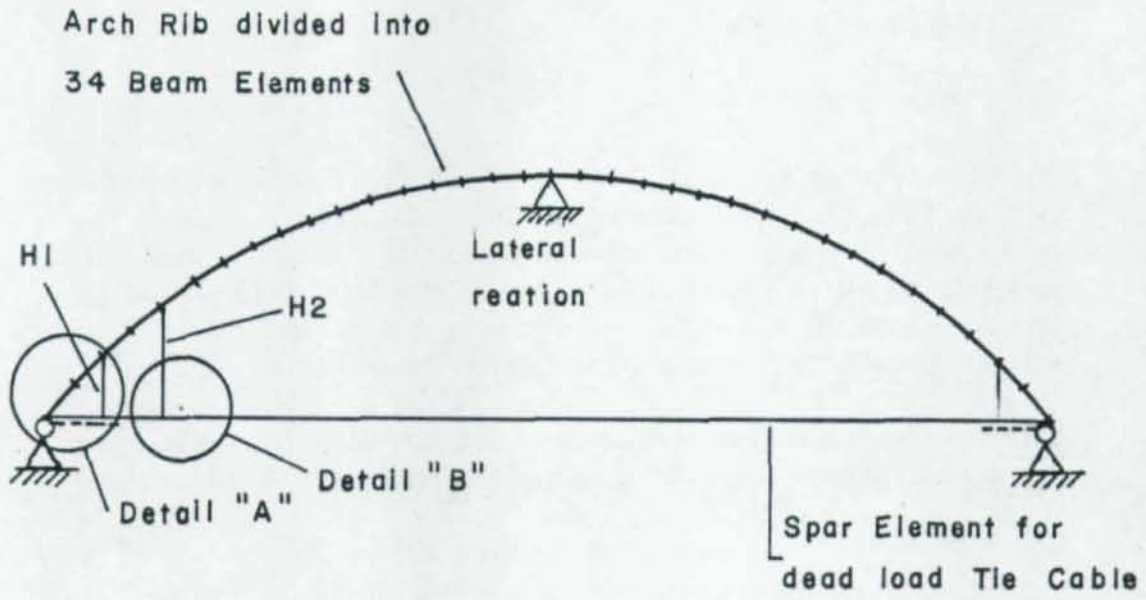

DETAIL "B"

ARCH RIB AND STAGING MODEL

Fig 4,2

#### 4.3.4 Bearings

Bearings are modeled using a special element that connects between the ground and the structure. It permits the user to specify a spring stiffness for any of 6 degrees of freedom. These elements are called Six-By Six elements (SBSs). An SBS is placed at each end of the arch rib. They were connected to the same nodes as the tie beam. The SBSs are specified rigid in the vertical and transverse directions and given zero rotational stiffness. The longitudinal stiffness is zero at one end of the arch rib and completely rigid at the other.

#### 4.3.5 Procedure

The first analysis is for the arch rib supporting its self weight. The results of this load are accumulated to the results of subsequent stages of placing deck units.

##### Stage 1-

The second analysis is made by adding the first four beam elements on each end of the structure. They are connected to the end of the arch rib and to the first hanger. Hanger are connected to the arch ribs. These units are shown in place in Figure 4.3A and B. This analysis represents the first pair of deck units placed on the structure. Although the units would actually be lifted singly, they are treated as if lifted in pairs and placed symmetrically. Units should be placed symmetrically in order to minimize bending in the arch ribs. The resulting analyses including moments and thrusts in the arch rib, hanger tension, tie cable tension and reactions are reported.

##### Stage 2-

In the second stage of construction, the stiffness of the beam elements representing the first pair of units is increased to their full live load stiffness. Loads representing weight of the first pair of units is then removed to avoid multiple counting. The first units are effectively stiffened by increasing the moment of inertia, but they are not connected to the arch ribs. The second pair of deck units are added to the model in a manner similar to the first. The weight of the second pair of units is placed on the correct nodes and their stiffness is small. This stage of analysis provides thrust and moment in the arch rib as well as some additional effects on hangers supporting the previous units.



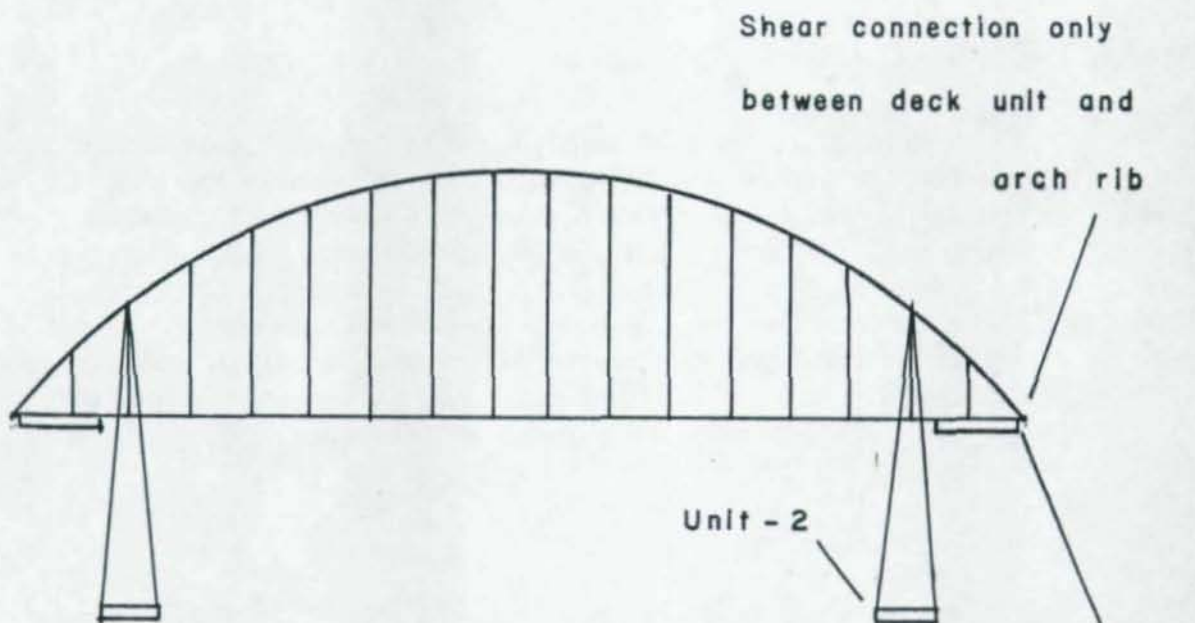

STAGE 2

Fig 4.3A

No bending stiffness  
between deck and arch  
during construction

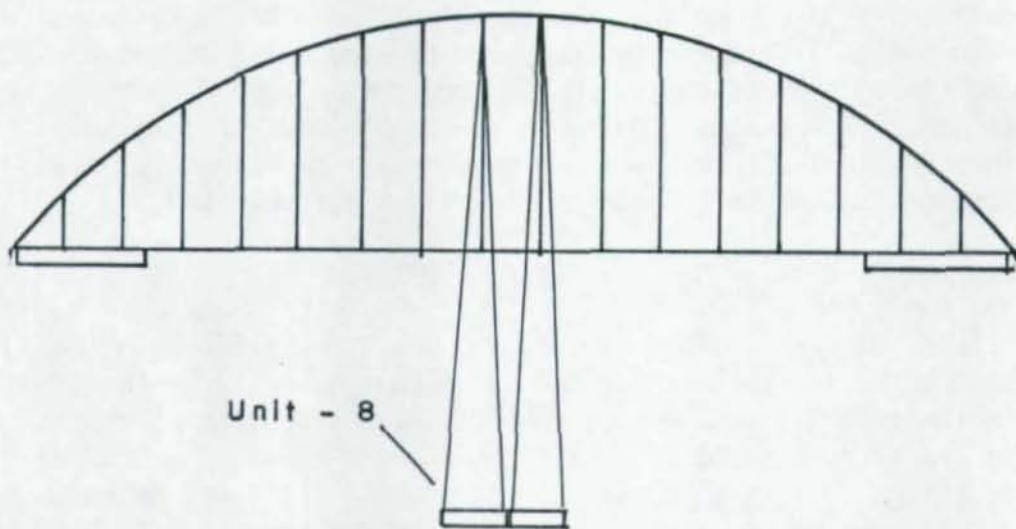

STAGE 3

STAGING OF DECK UNITS

Fig 4.3B

Bending in the tie beam at this stage must be accounted for by installing sufficient post tensioning across the joints between units. Moments in the tie beam are not reported but would be used to compute stresses in the tie beam and deck during erection. They are not computed because the model is crude and the value of moment is small.

#### Stage 3-

In this stage, two units are placed in the center of the span to reduce the negative moment that had accumulate in the center of the arch ribs. The procedure for analysis is the same as for the previous stages.

#### Stage 4-

In the analysis for stage 4, the units placed during Stage 3 are ignored and their loads are removed. The two units in Stage 4 are adjacent to the units in Stage 2.

#### Stages 5 and 7-

These stages are treated in the same manner as previous stages. The center units remain unconnected to the other units.

In an actual design, the engineer may wish to provide a full 3D analysis for each stage of deck unit placement. Study is required to determine the error permitted in placing the weight of the pair of units unevenly.

### 4.4 Integrated Model

#### 4.4.1 General

The integrated model is a full 3D model of the completed structure. The model is used to analyze for superimposed dead load, live load and thermal loads. The model is the same as the 2D staging model. with regard to the arch and tie cable and bearings.

#### 4.4.2 Tie Beam

The cross section of the tie beam model is composed of one plate element representing the web and two beam elements representing top and bottom flanges. All elements in the tie beam and deck model are 12'-2" long, which is the distance between floor beams. All tie beam properties are for concrete. Figure 4.4 shows the model of the tie beam and deck elements.



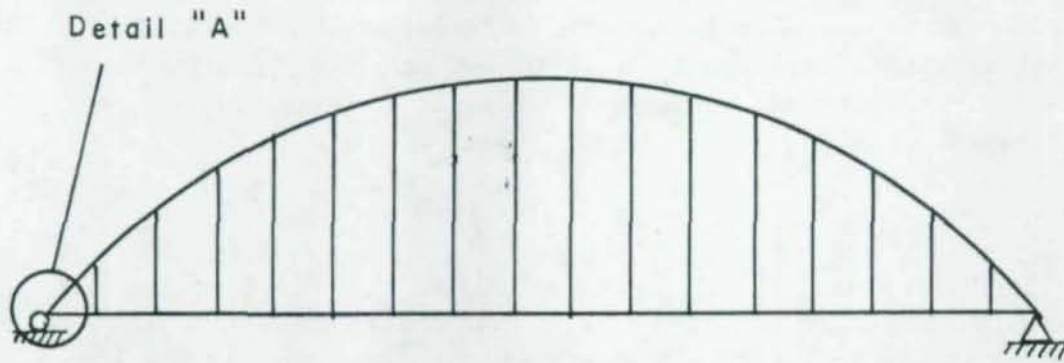

ELEVATION OF ARCH

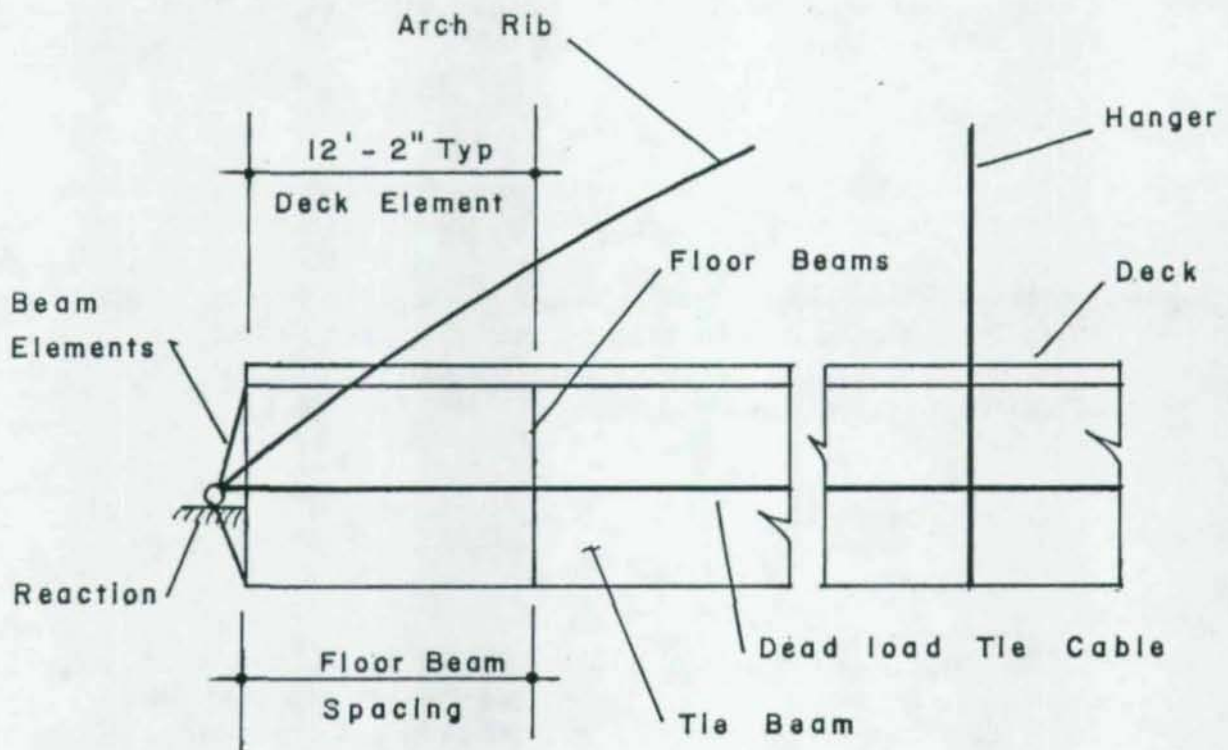

DETAIL "A"

INTEGRATED MODEL - OVERVIEW

Fig 4.4

The tie beam web is 9'-0" deep. Table 4.1 provides properties and sizes of the two designs examined. Design 1 was performed first and found to be too heavy. Design 2 was based on the results from Design 1.

Arches are connected to the tie beams at the midheight of the tie beams as shown in Figure 4.4. The nodes at these points are connected to the top and bottom of the tie beams with stiff beam elements to insure that a full moment connection is provided. This connection is slightly eccentric with respect to the center of gravity of the tie beam. Bearings were also placed at these nodes and were the same as for the 2D staging model.

#### 4.4.3 Deck

The top of the deck is positioned 1 foot above the top of the tie beam web in both designs. The deck is modeled by a series of 12 eight-node solid elements across the bridge between tie beams as shown in Figure 4.5. The portion of the deck outboard of the tie beams is modeled with another eight-node element as shown in Figure 4.5. There are a total of 728 deck elements in the integrated model.

#### 4.4.4 Floor Beams

The floor beams and deck are connected at four locations across the bridge. The connections are made with stiff beam elements. At the ends of the floor beam, the connection to the deck is the same element as that used for the tie beams. The four connections insure that the floor beam works compositely with the deck for rather uniform loads. It does not accurately represent the behavior for such loads as the barrier down the center of the bridge. The barrier was placed midway between connectors so the deck appeared more flexible than it should have appeared. Likewise, concentrated loads for live load analysis do not act correctly in the local region. However, they are more than sufficient for predicting overall structural behavior.

Floor beams are automatically connected to the top and bottom of the tie beams in the BRIDGE-SYSTEMsm. Since the tie beam is 9'-0" deep, the floor beams are 9'-0" deep at their ends instead of 5'-0". They became 5'-0" deep at third points. This causes some additional end stiffness in the floor beams. This did not affect design of the floor beams which are designed as simple spans. It would, however, tend to lead to the integrated model underestimating the stresses at mid-span of the floor beam compared to the simple span assumption used in their design.



TABLE 4.1 - MODEL EXPLANATIONS FOR FIGURE 4.5

Location	Description	Material	Property	
			Design 1	Design 2
A	Top flange of tie beam element	Concrete	.1 ft <sup>2</sup>	Same
B	Web of tie beam Plate elem.	Concrete	1.0 ft	.75 ft
C	Bottom flg of tie beam element	Concrete	6 ft <sup>2</sup>	2 ft <sup>2</sup>
D	Bottom flg of floor beam Bm elem	Steel	30 in <sup>2</sup>	Same
E	Web of flr beam plate elem.	Steel	.5625 in	Same
F	Top flg of flr beam plate elem.	Steel	10 in <sup>2</sup>	Same
G	Joint between floor lm elems.			
H	Deck Nodes 8-node solids	Concrete	See Dtl.	
I&J	Arch Rib Beam Elements	Steel	324 in <sup>2</sup>	Same
			131000 in <sup>4</sup>	Same
K&L	Hanger spar Elem.	Cable	3.6 in <sup>2</sup>	7.2 in <sup>2</sup>
M	Tie Cable Spar elem.	Cable	72. in <sup>2</sup>	Same
S	Stud conn. Bm. Elem.	Steel	1.0 ft <sup>2</sup>	Same
		MOI	4000ft <sup>4</sup>	Same

## MATERIAL PROPERTIES

	YOUNG'S MODULUS	POISSON'S RATIO
STEEL	29000000 psi	0.30
CONCRETE		
LIVE LOAD	5400000 psi	0.15
SUP DEAD LOAD	1900000 psi	0.15
CABLE	28000000 psi	0.3

## DETAIL MODEL EXPLANATIONS

- 1-2-3-4 Connectivity of end of 8-node solid deck element
- 3-7-4 Connectivity of beam stud element
- 7-9 Connectivity of top flange of floor beam
- 8-10 Connectivity of bottom flange of floor beam
- 7 Connectivity of bottom of hangers





#### 4.4.5 Procedure

Superimposed dead load was analyzed first using the integrated model. In this case the wearing surface is considered by introducing an artificial density to the 8-node deck elements. This results in a load equal to the weight of the wearing surface being applied rather uniformly to the structure. Parapets are modeled with longitudinal rows of concentrated loads along the bridge at each node where parapets or barriers are located. The concrete modulus is decreased to one-third the normal value for this analysis to account for creep and shrinkage. The tie cable is considered effective.

In the live load analysis, the modulus was changed to the full value. A series of load cases are examined where each case considers a single concentrated load applied to the deck at prescribed locations. There is a load case for a total of 18 lines of loads applied along the span. A line of loads is applied at each hanger line and reaction line. Each load line consists of 9 loads. The results of these 162 load cases are saved for a large number of responses including arch moments, deck stresses, hanger stresses, reactions, etc. Influence surfaces with 162 values each are built from these responses.

Each influence surface is then subjected to a searching technique to determine the location of the specified vehicles which cause the maximum and minimum response within the prescribed limitations of AASHTO. A comparison with the original design live load values is made for certain cases in Section 5 - Results.

Local bending in the deck due to live and dead loads is computed by hand according to AASHTO-3.24.3.2. This method does not allow for the flexibility of the floor beams. It also is thought to be rather conservative. Influence surfaces based on the deck and floor beams is expected to yield lower bending stresses.

The temperature effect is analyzed using the same integrated model as for live load. Temperature of the arch ribs, hangers and the dead load tie cable is increased 100 degrees Fahrenheit above the concrete.

The amount of post tensioning in the deck and tie beams is determined by finding the sum of the critical stresses in the deck and in the tie beam based on the above analyses.

Preliminary examination of the concrete stresses in Design 1 indicated that the model should be modified to consider a thinner deck at the tie beams and thicker in the center. The bottom flange of the tie beams as well as the webs of the tie beams were found to be too large. It was also learned that only half of the correct hanger cable area had been used. A modified integrated model was then built and the same runs performed again. Results of Design 2 were reported under Section 5 - Results.



## 5.0 RESULTS

### 5.1 General

This section reports the results of the analyses described in Section 4. The floor beams results are based on the simple span analysis which was done by hand. Results for the arch ribs, hangers, dead load tie cable, tie beam, reactions and deck were all determined from the 2D and 3D analyses. They are reported in summary form with results combined according to AASHTO Cases.

Results are first reported in response terms such as moments and thrust for each load condition where appropriate. These responses are then converted into stresses and combined in the appropriate load cases. Case I is AASHTO CASE I and Case II is AASHTO CASE IV from Table 3.22.1.A for Load Factor Design. Appropriate cases are also considered for determining the amount of post tensioning according to AASHTO Section 9.16.2.

### 5.2 Floor Beams

Figure 5.1 shows the moment envelope for the simple span analysis. The controlling live load moment for strength is caused by the Interstate load; and the controlling loading for fatigue is the HS20 vehicle loading. The controlling load condition was all six lanes of traffic placed as close as possible to the point of consideration.

All dead load is placed on the composite section based on the assumption that the floor beams be fully shored during casting of the deck unit. Further, there has been no consideration for lateral buckling of the top flange. This permits the top flanges of the floor beams to be made rather small.

Figure 5.2 shows the shear envelopes. Shear connector design is controlled by fatigue which is related to shear range.

Figure 5.3 shows the floor beam. The weight is 16.2 pounds per square foot of deck compared to 36 pounds per square foot for the steel in the floor system of the original design.

The maximum live load bending stress in the bottom of the floor beams based on the simple span analysis was 13 ksi including impact. This compared to 7 ksi based on the integrated model. The integrated model results were based on loading the influence surface for the axial stress in the beam element bottom of the floor beam at the center of the center element. The integrated model was not developed to properly model the floor beams.

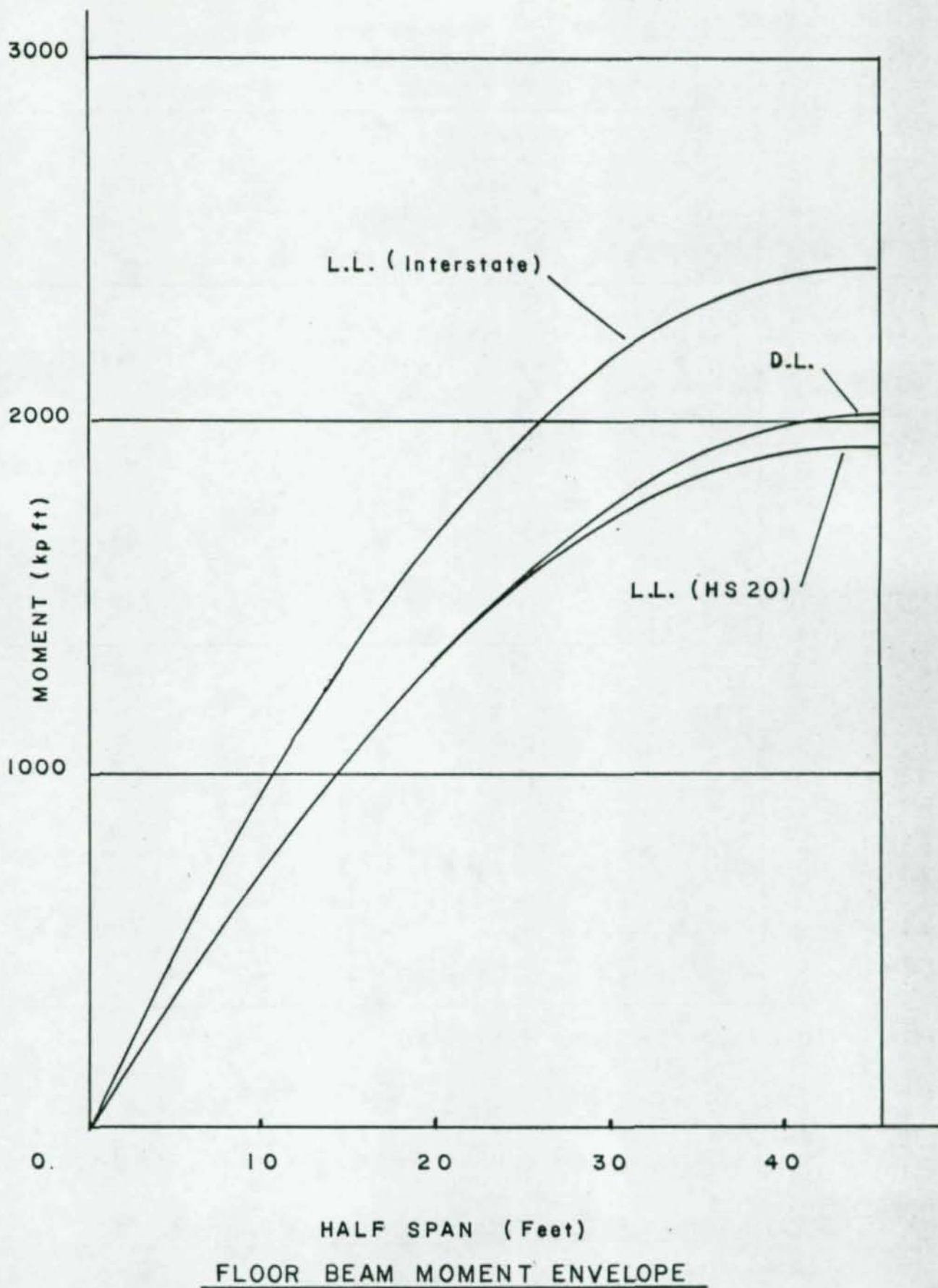
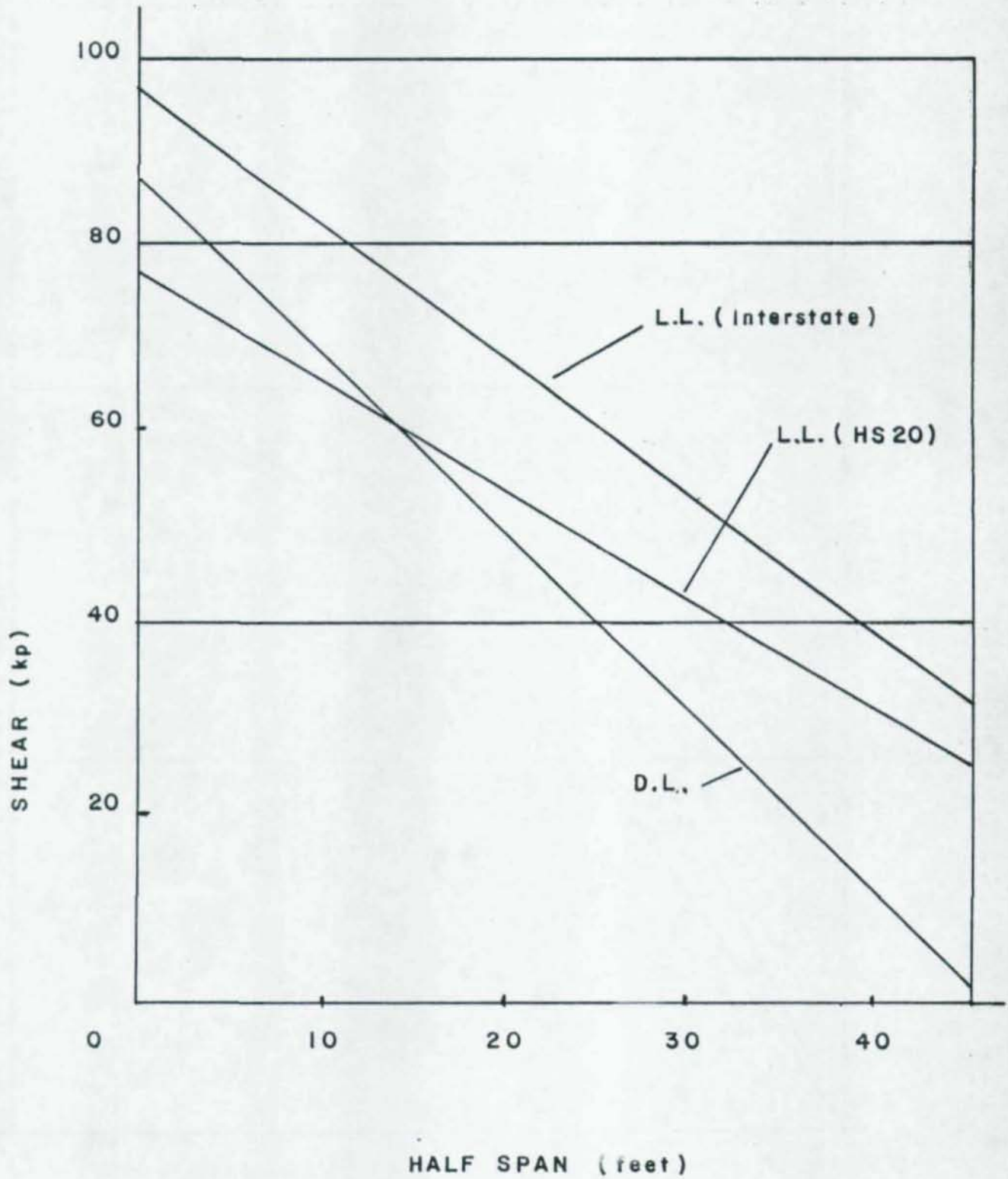

Fig 5.1





FLOOR BEAM SHEAR ENVELOPE

Fig 5.2

With only four connecting nodes per floor beam between the deck and the steel, the concentrated unit loads are not distributed to the floor beam correctly. When unit loads are placed over the nodes with beam stud connectors to the floor beam, the load is transferred directly to the floor beam, but when concentrated loads are placed between these studs, the load is distributed to adjacent floor beams as well as to the one under consideration. Figure 5.4 shows the influence line for the stress in the bottom of the floor beam based on the 3D model. Also, for comparison the influence line based on a simple span is shown. The influence line from the 3D model is truncated in the center because there is no stud in the center of the span.

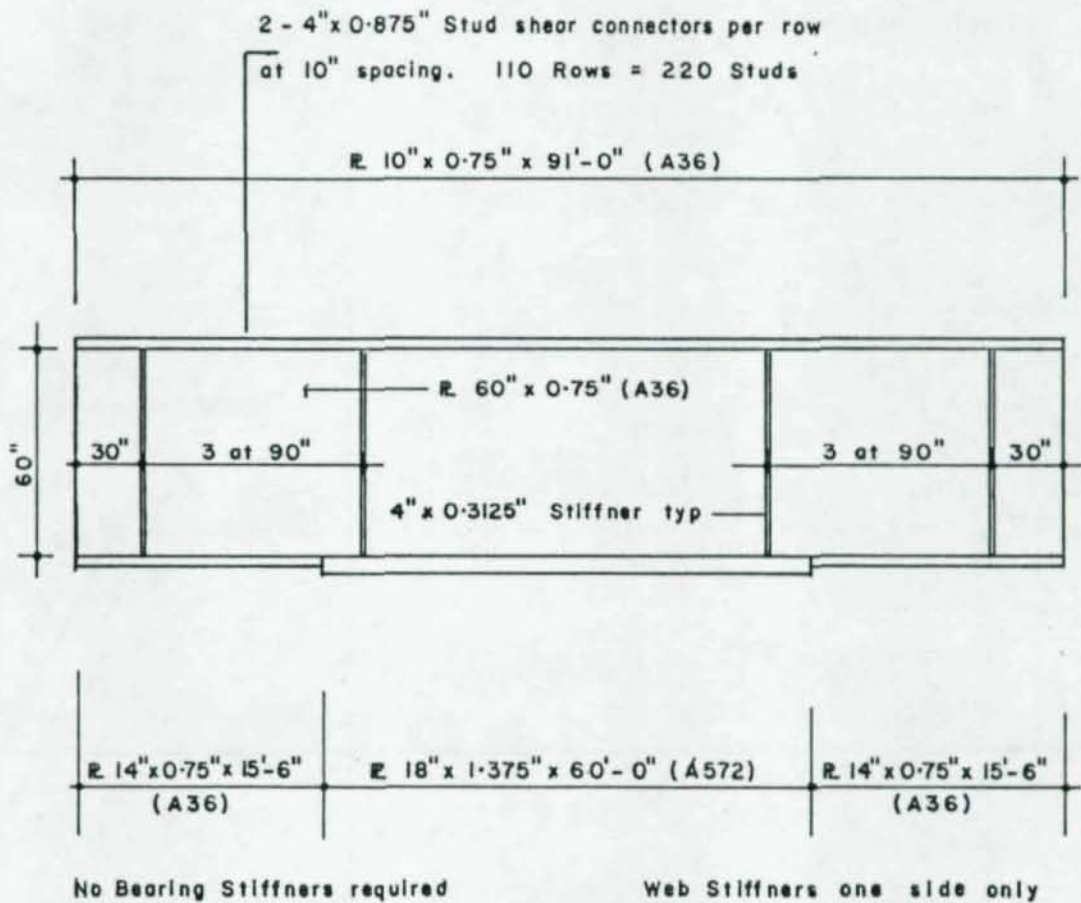

TYPICAL FLOOR BEAM

Fig 5,3



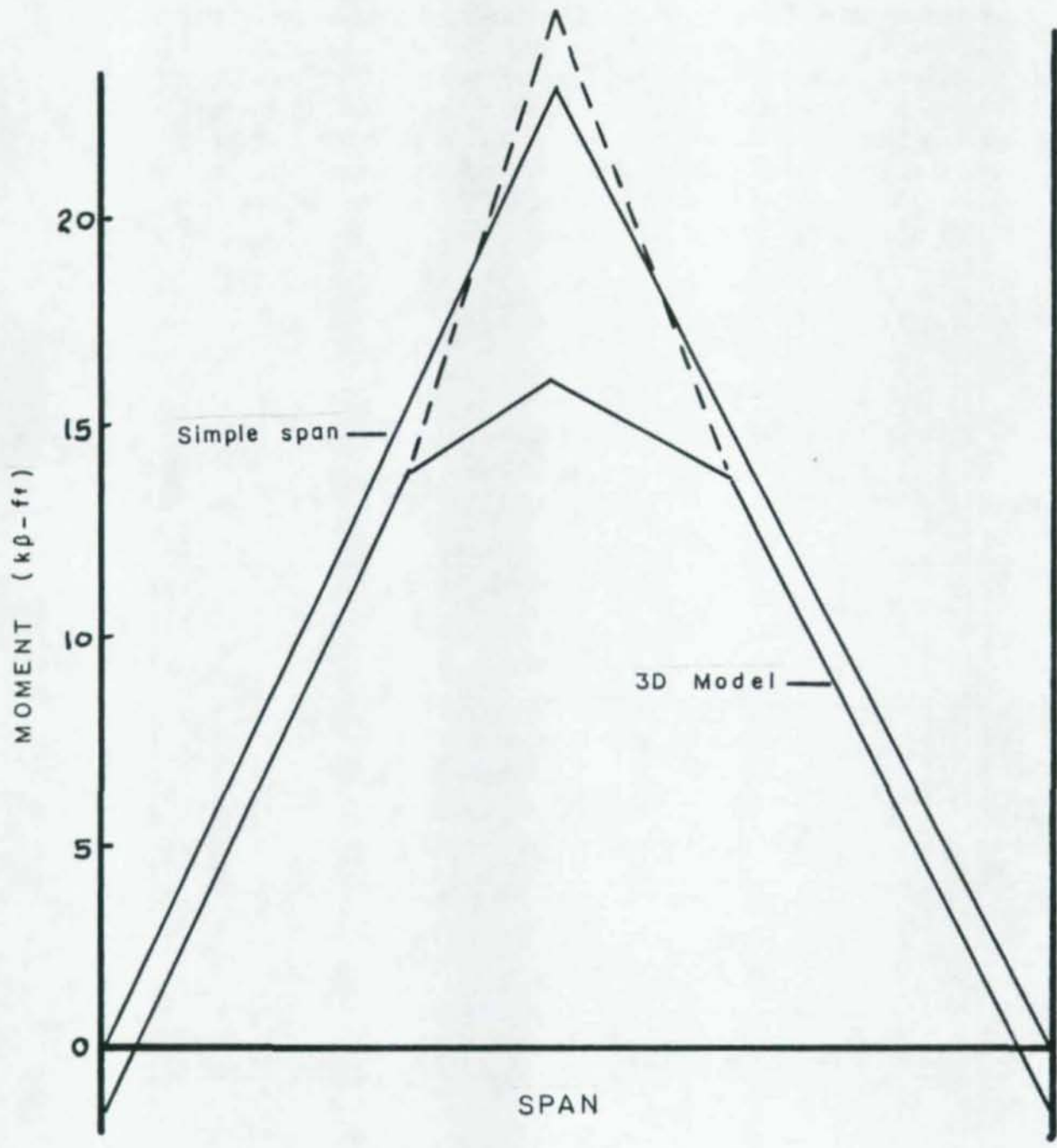

FLOOR BEAM INFLUENCE LINE

Fig 5.4

### 5.3 Arch Ribs

#### 5.3.1 General

Since the arch ribs were modeled as a series of beam elements, the moment and thrust responses could be reported directly. Further, since the arch rib model did not change between the 2D and integrated model, no transformations were required before the results could be combined.

#### 5.3.2 Deck Unit Staging

Arch ribs moments at hanger locations are presented in Table 5.1 for each stage of deck unit placement. Comparable thrusts are presented in Table 5.2. Section 4.3.3 describes in detail the sequence of deck unit placement.

TABLE 5.1 - DEAD LOAD MOMENTS IN ARCH RIB DUE TO STAGING  
(FT-K)

Location	0	1	2	3	4	5	6	7	8
ARCH ONLY	0	378	514	470	326	137	-49	-194	-273
DL UNIT 1	728	10139	6700	3755	1300	-664	-2140	-3120	-3611
DL UNIT 2	-752	5600	12380	7194	2872	-584	-3176	-4905	-5770
DL UNIT 8	418	-3986	-9155	-10400	-9324	-5938	-240	7772	18097
DL UNIT 3	-116	1710	6476	11778	5527	526	-3224	-5724	-6975
DL UNIT 4	108	-135	1044	4576	9398	3040	-1726	-4905	-6495
DL UNIT 5	108	-1603	-1987	-1020	1892	7099	1470	-2282	-4160
DL UNIT 6	117	-2871	-4327	-4390	-3030	222	6520	2305	198
DL UNIT 7	131	-3789	-6066	-6808	-6009	-3533	1237	9102	6828

TABLE 5.2 - DEAD LOAD THRUSTS IN ARCH RIB DUE TO STAGING  
(KIPS)

Location	0	1	2	3	4	5	6	7	8
ARCH ONLY	-531	-504	-482	-464	-448	-437	-428	-423	-421
DL UNIT 1	-333	-119	-124	-129	-133	-137	-140	-142	-143
DL UNIT 2	-418	-402	-218	-227	-234	-242	-247	-250	-251
DL UNIT 8	-768	-727	-754	-754	-750	-740	-724	-701	-672
DL UNIT 3	-484	-506	-488	-328	-340	-349	-357	-361	-363
DL UNIT 4	-573	-570	-577	-566	-432	-444	-454	-460	-462
DL UNIT 5	-654	-647	-639	-636	-632	-524	-536	-543	-545
DL UNIT 6	-717	-711	-702	-693	-685	-683	-601	-609	-612
DL UNIT 7	-762	-756	-748	-739	-729	-721	-711	-657	-660



TABLE 5.3 - ACCUMULATED DEAD LOAD MOMENTS IN ARCH RIB DUE TO STAGING  
(FT-K)

Location	0	1	2	3	4	5	6	7	8
ARCH ONLY	0	378	514	470	326	137	-49	-194	-273
TOTAL UN1	728	10517	7214	4225	1626	-527	-2189	-3314	-3884
TOTAL UN2	741	16276	19586	11408	4486	-1125	-5378	-8235	-9668
TOTAL UN8	755	10471	10437	1048	-4776	-6979	-5513	-341	8564
TOTAL UN3	755	13162	17037	12783	698	-6513	-8803	-6136	1517
TOTAL UN4	755	13132	18575	17453	10039	-3538	-10601	-11117	-5056
TOTAL UN5	755	10853	15887	16235	12145	3675	-9006	-13267	-9079
TOTAL UN6	755	6842	9953	10468	8634	4509	-1894	-10334	-8235
TOTAL UN7	755	1656	1817	1617	1307	932	553	75	-62

TABLE 5.4 - ACCUMULATED THRUST ARCH DUE TO STAGING  
(KIPS)

Location	0	1	2	3	4	5	6	7	8
ARCH ONLY	-531	-504	-482	-464	-448	-437	-428	-423	-421
TOTAL UN1	-864	-623	-606	-593	-581	-574	-568	-565	-564
TOTAL UN2	-1282	-1025	-824	-820	-815	-816	-815	-815	-815
TOTAL UN8	-2050	-1752	-1578	-1574	-1565	-1556	-1539	-1516	-1487
TOTAL UN3	-2534	-2258	-2066	-1902	-1905	-1905	-1896	-1877	-1850
TOTAL UN4	-3107	-2828	-2643	-2468	-2337	-2349	-2350	-2337	-2312
TOTAL UN5	-3761	-3475	-3282	-3104	-2969	-2873	-2886	-2880	-2857
TOTAL UN6	-4478	-4186	-3984	-3797	-3654	-3556	-3487	-3489	-3469
TOTAL UN7	-5240	-4942	-4732	-4536	-4383	-4277	-4198	-4146	-4129

Accumulated moments and thrusts for each stage are plotted in Figure 5.5 and 5.6, respectively. It is evident that the moment in the arch rib in the vicinity the deck unit being placed is positive while in other locations it is negative. In order to keep moments in the arch more evenly balanced, the two center deck units were added as the third stage. These units would not be lifted into place, but suspended from the arch.

ACCUMULATED ARCH MOMENTS (kpft)

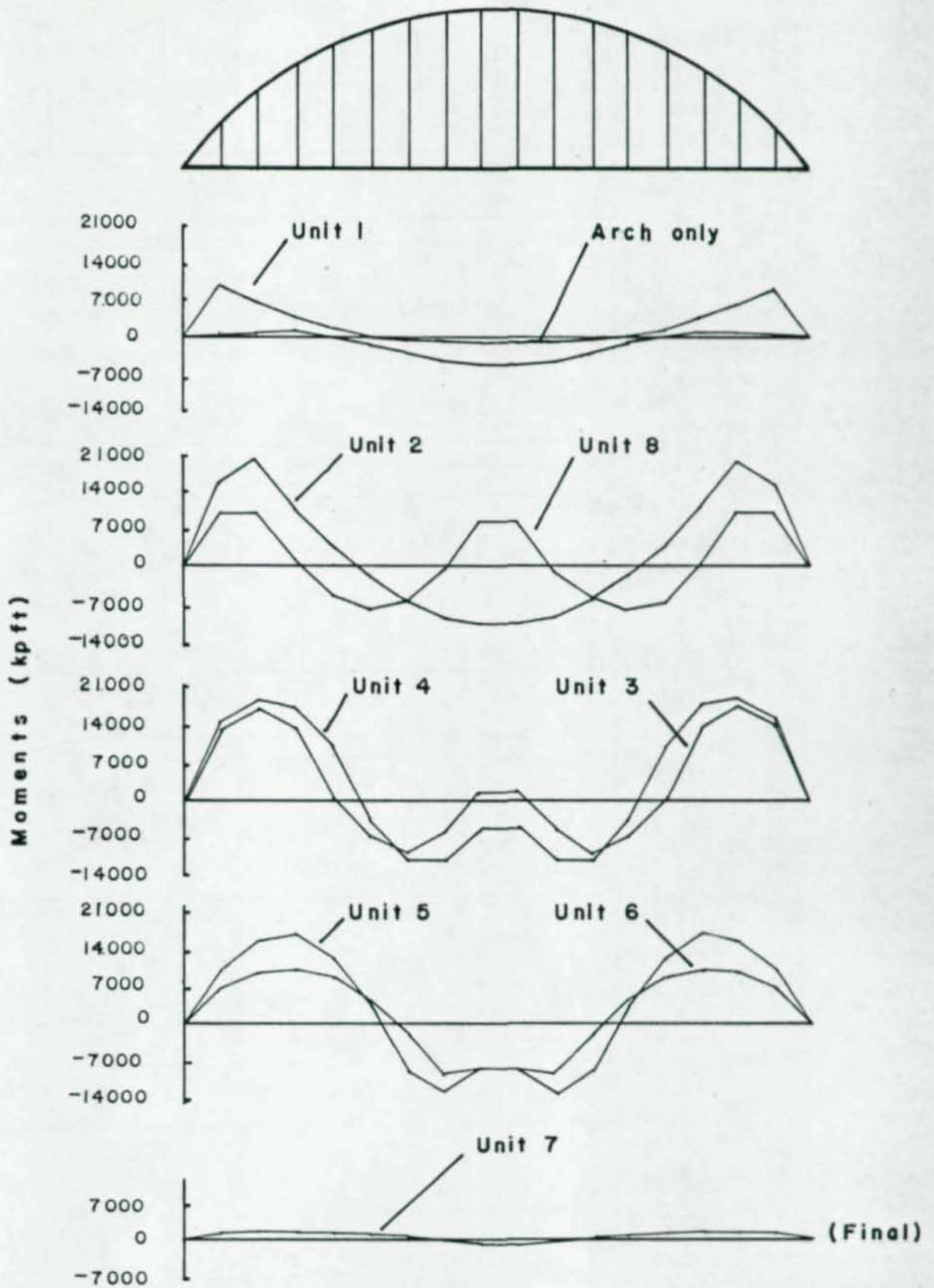

Fig 5.5



ACCUMULATED TRUST IN ARCH RIB (kp)

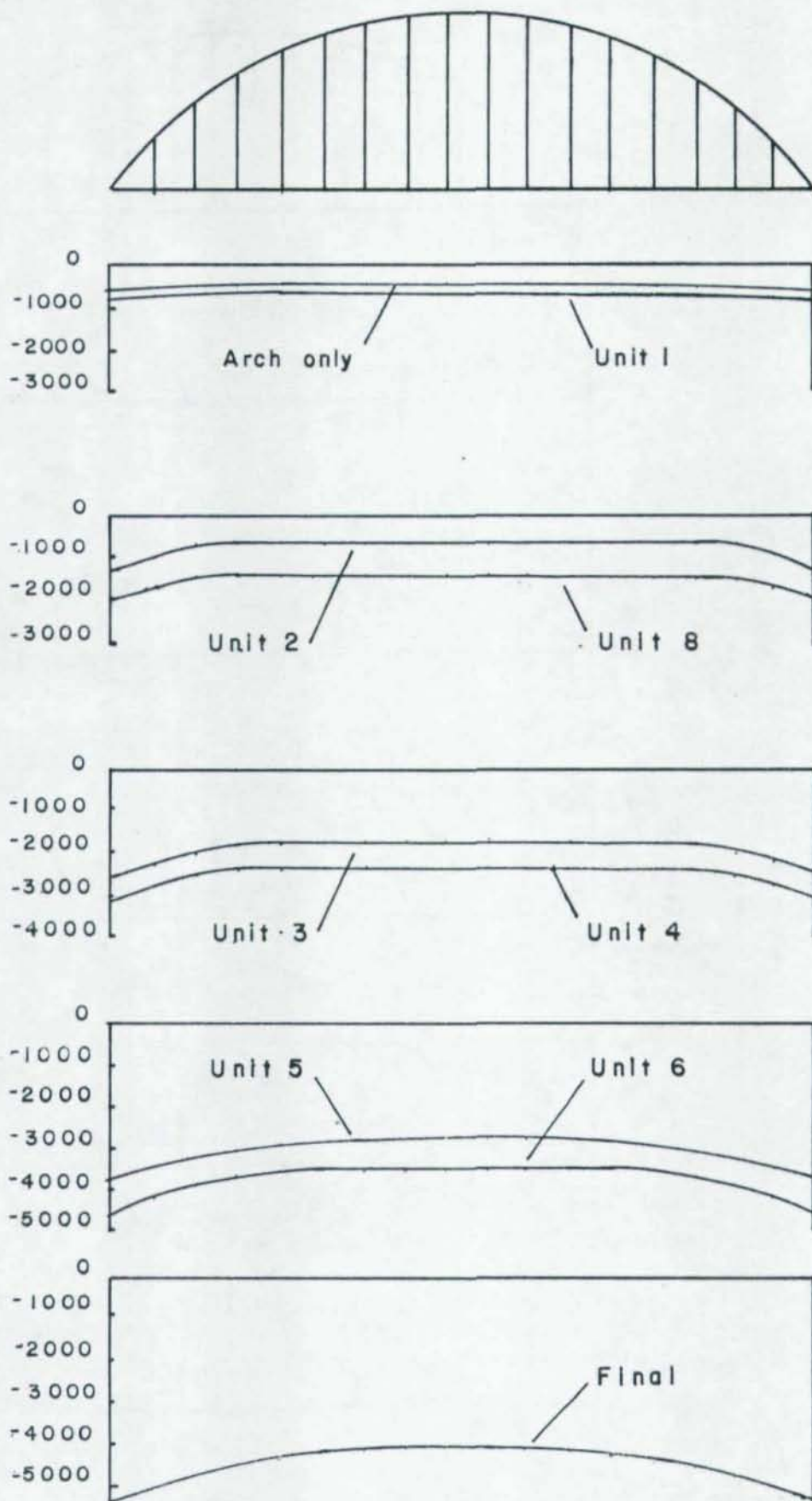

Fig 5,6

Resulting stresses in the arch rib for each stage of loading are shown in Table 5.5. They were determined by summing the stresses from the moments and thrust in Tables 5.3 and 5.4.

TABLE 5.5 - ACCUMULATED STRESS IN TOP OF ARCH RIB  
DUE TO STAGING  
(KSI)

Location	0	1	2	3	4	5	6	7	8
ARCH ONLY	-1.6	-2.4	-2.6	-2.5	-2.1	-1.6	-1.2	-0.9	-0.7
TOT UN1	-4.3	-25.1	-17.7	-11.1	-5.4	-0.6	3.1	5.5	6.8
TOT UN2	-5.6	-39.0*	-45.6	-27.6	-12.4	0.0	9.0	15.6	18.8
TOT UN8	-8.0	-28.4	-27.8	-7.2	5.7	10.6	7.4	-3.9	-23.4*
TOT UN3	-9.5	-35.9	-43.9	-34.0	-7.4	8.4	13.5	7.7	-9.0
TOT UN4	-11.2	-37.6	-49.0*	-46.0*	-29.3	0.5	16.1*	17.2	4.0
TOT UN5	-13.3	-34.6	-45.1	-45.3	-35.9*	-17.0	10.9	20.3*	11.2
TOT UN6	-15.5	-28.0	-34.2	-34.7	-30.3	-20.9*	-6.6	12.0	7.4
TOT UN7	-17.8*	-18.9	-18.6	-17.6	-16.4	-15.2	-14.2	-13.0	-12.6

ACCUMULATED STRESS IN BOTTOM OF ARCH RIB  
DUE TO STAGING  
(KSI)

Location	0	1	2	3	4	5	6	7	8
TOT ARCH	-1.6	-0.7	-0.4	-0.4	-0.7	-1.0	-1.4	-1.7	-1.9
TOT UN1	-1.1	21.2	14.0	7.5	1.8	-2.9	-6.6	-9.0	-10.3
TOT UN2	-2.3	32.6*	40.5*	22.6	7.4	-5.0	-14.3	-20.6	-23.8
TOT UN8	-4.7	17.6	18.1	-2.6	-15.3	-20.2*	-16.9	-5.4	14.3
TOT UN3	-6.2	22.0	31.1	22.3	-4.3	-20.2*	-25.2	-19.3	-2.4
TOT UN4	-7.9	20.2	32.7	30.8*	14.9	-15.0	-30.6*	-31.7	-18.3
TOT UN5	-9.9	13.2	24.8	26.1	17.6*	-0.8	-28.7	-38.1*	-28.8*
TOT UN6	-12.2	2.1	9.6	11.3	7.7	-1.1	-14.9	-33.5	-28.8*
TOT UN7	-14.5*	-11.6	-10.6	-10.4	-10.7	-11.1	-11.7	-12.6	-12.9

$$\text{STRESS} = (\text{MOMENT (FT-K)} \times 12) \times (C=24) / I=131000 \text{ IN}^4 +$$

$$(\text{THRUST (KIPS)} / \text{AREA}=324 \text{ SQ. IN.})$$

Asterisks identify maximum stresses.



Figure 5.7 shows the stress envelope of maximum tensile and maximum compressive stresses in the arch rib during placement of the deck units. The envelopes are based on Table 5.5. They demonstrate the critical locations. The unfactored stress in both top and bottom of the arch rib approach the yield stress so the section of the arch rib could be increased, or the erection sequence might be modified to lower stresses. A factor of safety of at least 1.25 would be expected. Stresses in the arch rib after all deck units have been placed are plotted on the same figure for comparison. The thrust is seen to be about 15 ksi while the bending stress does not exceed 10 ksi. During staging, moment dominated the loading over thrust. The parabolic shape of the arch ribs keeps bending to a minimum when loads are applied uniformly along the span.

Although it is not practical to lift two units at opposite ends of the span simultaneously, no analysis was performed to consider single units placed in an unsymmetrical manner. It is thought that some error should be permitted in simultaneously lifting two units. The effect of this error can easily be determined and should be considered when determining a factor of safety. Another possibility is to join two units prior to lifting. This would permit using the hanger locations to attach the hoist cables without the units becoming unstable or introducing a different hanger arrangement.

### 5.3.3 Superimposed Dead Load

The superimposed dead load is composed of the wearing surface and barriers. Results for moment and thrust are presented in Tables 5.6 and 5.7, respectively. Thrust is large with respect to the moment compared to the staging results. This is expected for loads applied uniformly along the span.

96960

# ARCH CONSTRUCTION STRESSES (ksi)

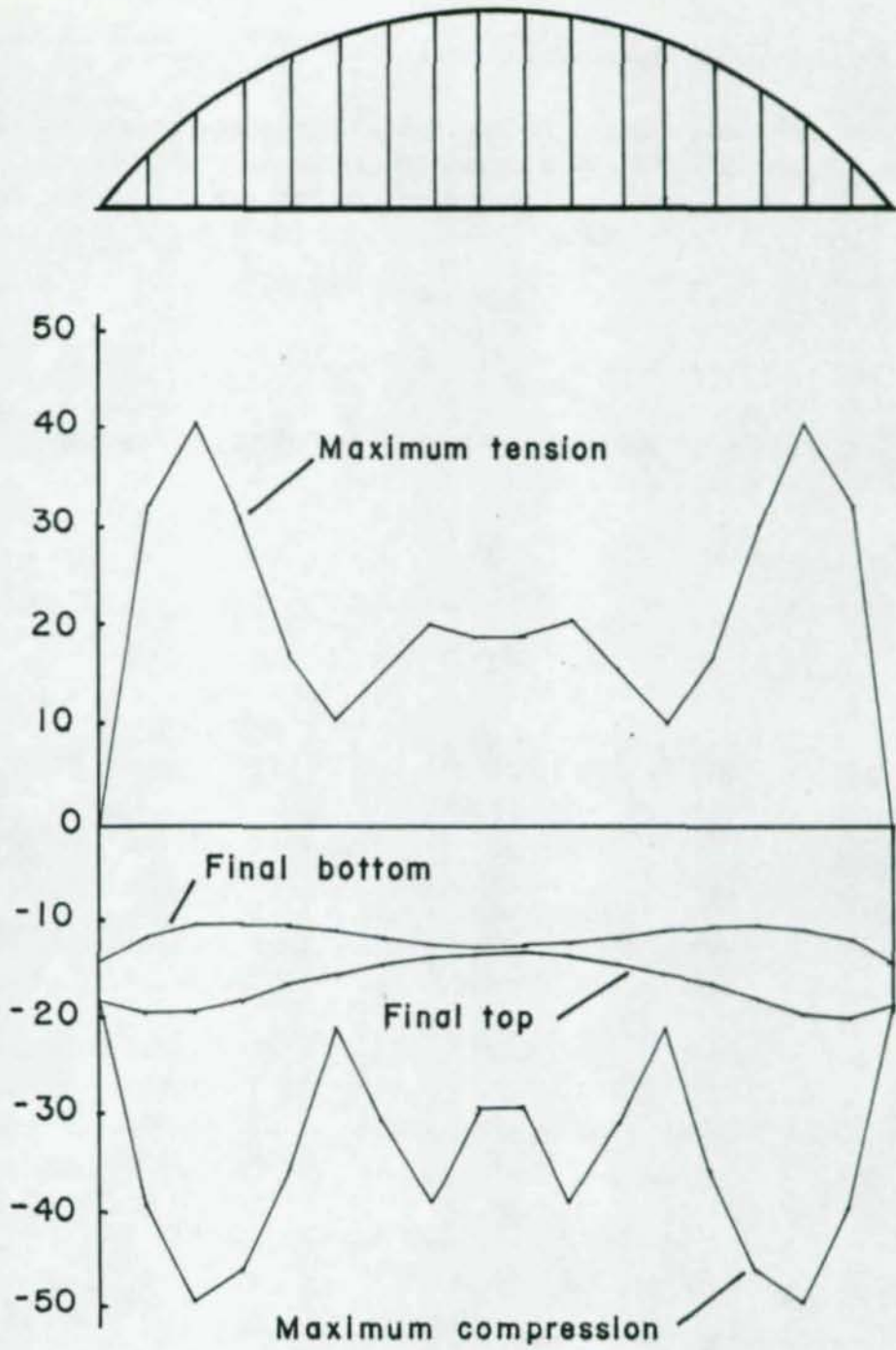

Fig 5.7



## 5.3.4 Temperature

The results of the thermal analysis are presented in Tables 5.6 and 5.7. In this case, the force is caused by the arch attempting to expand and tension in the hangers attempting to restrain the arch from rising. These actions cause a positive moment in the arch ribs.

TABLE 5.6 - SUMMARY OF ARCH RIB MOMENTS  
(FT-K)

Hanger Loc ->	0	1	2	3	4	5	6	7	8
DL	755	1656	1817	1617	1307	932	553	75	-62
Original DL	1048	765	924	970	940	934	936	842	863
SIMP	874	132	64	73	68	54	39	28	22
OriginalSup	314	124	102	110	117	125	132	136	139
TEMP	3151	3174	3177	3176	3173	3170	3167	3163	3159
LL+I (+)	799	202	409	596	648	644	574	443	386
LL+I final	961	585	880	1111	1222	1201	1057	836	693
Orig LL+I	556	777	1229	1442	1509	1444	1254	1002	842
LL+I (-)	-74	-238	-461	-555	-596	-561	-468	-345	-234
LL+I final	-377	-461	-754	-993	-1115	-1112	-983	-759	-598
Orig LL+I	134	-455	-899	-1084	-1167	-1111	-945	-693	-476

TABLE 5.7 - SUMMARY OF ARCH RIB THRUSTS  
(KIPS)

Hanger Loc ->	0	1	2	3	4	5	6	7	8
DL	-5240	-4942	-4732	-4536	-4383	-4277	-4198	-4146	-4129
Orig DL	-4736	-4712	-4516	-4131	-4169	-4033	-3925	-3846	-3800
SIMP	-1215	-1172	-1125	-1082	-1046	-1017	-998	-983	-981
Orig Sup	-476	-476	-458	-440	-423	-409	-398	-390	-385
TEMP	-93	-88	-84	-81	-79	-77	-75	-74	-74
LL+I	-907	-878	-845	-801	-785	-763	-749	-739	-736
LL+I final	-425	-410	-393	-378	-366	-355	-349	-343	-342
Orig LL+I	-836	-836	-805	-773	-745	-720	-701	-686	-677

The appropriate temperature range to be used is a qualitative matter to be considered in design which is beyond the scope of this study. However, it is suggested that 100 degrees is excessive. The range would depend on the color of the metal parts and on the environment.

#### 5.3.5 Live Load

The live load responses were determined for both moment and thrust in the arch ribs. Both maximum and minimum values are given for each in Table 5.5 and 5.6 respectively. In this study, coincident values were not determined even though they are required for design. In this case, construction controlled the arch rib design so it may be unnecessary to examine coincident responses.

The BRIDGE-SYSTEMsm is capable of performing such an analysis of coincident loading if necessary. It simply saves the load positions for one loading and applies them to another influence surface.

Values of maximum moment and thrust from the original design are also presented for comparison. The final run was made using a thinner deck at the tie beams, 1'-3", and thicker in the center, 9.0". The hanger cables were doubled in size and the tie beams were modified as shown in Figure 4.1. The first analysis will be referred to as Design 1. The other as Design 2. Positive moments in Design 1 are generally lower than in the original design, whereas in Design 2, they were nearly the same. The reason is that in Design 1 the deck system is much stiffer and distributes load more evenly over the hangers. This is consistent with the observation of the staging loads which produce positive moments only above the unit. Conversely, Design 2 permits more concentration of loads since the deck is more flexible. Design 2 closely approximates the original design values in both senses.

Thrusts are similar between Design 1 and the original design. This result is understandable in that the same surface of deck should be loaded in either case and the results are not dependent on deck stiffness. Thrust in Design 2 is less than in Design 1 because the tension area is significantly less and the arch ribs elongate more under load. This is consistent with the observed larger arch moments in Design 2.

The moment results are combined in Table 5.8 for each case to determine the controlling condition which is used to compute arch rib stresses. Table 5.9 is a similar compilation for thrust.



TABLE 5.8 - FACTORED MOMENTS IN ARCH RIB  
(K-FT)

Hanger Loc ->	0	1	2	3	4	5	6	7	8
DL	755	1656	1817	1617	1307	932	553	75	-62
SIMP	874	132	64	73	68	54	39	28	22
TEMP	3151	3174	3177	3176	3173	3170	3167	3163	3159
LL+I final	961	585	880	1111	1222	1201	1057	836	693
LL+I final	-377	-461	-754	-993	-1115	-1112	-983	-759	-598
CASE I +	3833	7686	8222	8088	5331	1862	-433	-1540	-1944
CASE I final	4200	3593	4351	4603	4435	3883	3060	1945	1450
CASE I -	1941	6733	6337	5593	2635	-748	-2689	-3246	-3288
CASE I final	1302	1325	811	46	-628	-1127	-1361	-1510	-1348
CASE II +	7236	11637	11997	11700	8894	5425	3187	2188	1828
CASE II final	7463	7211	7719	7770	7501	6964	6261	5332	4956
CASE II -	6101	11065	10866	10203	7276	3859	1834	1164	1021
CASE II final	5724	5851	5595	5035	4463	3958	3608	3260	3277
CASE I	3833	7686	8222	8088	5331	1862	-2689	-3246	-3288
CASE I final	4200	3593	4351	4603	4435	3883	3060	1945	1450
CASE II	7236	11637	11997	11700	8894	5425	3187	2188	1828
CASE II final	7463	7211	7719	7770	7501	6964	6261	5332	4956

TABLE 5.9 - FACTORED THRUST IN ARCH RIB  
(KIPS)

DL	-5240	-4942	-4732	-4536	-4383	-4277	-4198	-4146	-4129
SIMP	-1215	-1172	-1125	-1082	-1046	-1017	-998	-983	-981
TEMP	-93	-88	-84	-81	-79	-77	-75	-74	-74
LL+I	-907	-878	-845	-801	-785	-763	-749	-739	-736
CASE I	-10357	-9851	-9445	-9039	-8759	-8535	-8378	-8269	-8238
CASE I final	-9312	-8836	-8465	-8122	-7851	-7652	-7511	-7412	-7385
CASE II	-9692	-9204	-8822	-8450	-8181	-7974	-7826	-7725	-7696
CASE II final	-9065	-8595	-8234	-7900	-7636	-7444	-7306	-7210	-7184

The stresses in the arch rib are summarized for all cases in Table 5.10. Subsequently, they are factored and combined into the two cases described earlier. It is seen that the arch rib is slightly overstressed at several locations when the temperature condition is considered in Design 1. Temperature accounts for the overage in every case. Without temperature, the arch is satisfactory with regard to final stresses in this case. The temperature condition, as stated earlier, is believed to be very conservative. There is no overage in the final case. The reasons were discussed earlier.

TABLE 5.10 - SUMMARY OF STRESSES IN TOP AND BOTTOM OF ARCH RIB

STRESS TOP (KSI)

CASE I	-41	-48	-48	-46	-39	-31	-20	-18	-18
CASE I final	-38	-35	-36	-35	-34	-32	-30	-27	-26
CASE II	-46	-54	-54	-52	-45	-37	-31	-29	-28
CASE II final	-44	-42	-42	-41	-40	-38	-36	-34	-33

STRESS BOTTOM (KSI)

CASE I	-23	-13	-10	-9	-15	-22	-32	-33	-33
CASE I final	-19	-19	-17	-15	-14	-15	-16	-19	-20
CASE II	-14	-2	-0	0	-5	-13	-18	-20	-20
CASE II final	-12	-11	-8	-7	-7	-8	-9	-11	-11

#### 5.4 Hangers

##### 5.4.1 General

The hangers are vertical in both analyses. In Design 1 the hanger area is 3.5 in<sup>2</sup>, whereas it is twice that in Design 2. The original design has hanger areas of about 7 in<sup>2</sup>. There are actually four hanger cables in the actual arrangement. If the alternate arrangement of inclined hangers is used, there will be only two hanger cables per attachment.



## 5.4.2 Dead Load

The deck units were placed on the structure as described in Section 4. The force in the first hanger is the weight of half of the deck unit. Table 5.11 shows the hanger forces for each stage of loading. Some of the forces change as subsequent loads are added because of the stiffness that was assumed effective between the units after they are placed. Stage three is out of the normal sequence because it is the center two deck units which were placed to balance arch rib moments. Table 5.12 shows the accumulated hanger dead load forces. In Table 5.13 they are compared to the original dead loads. It is interesting that the dead load of the deck in Design 2 is nearly balanced by the additional steel weight of the original design.

TABLE 5.11 - HANGER FORCES FOR DEAD LOAD STAGING  
(KIPS)

Hanger Loc ->	1	2	3	4	5	6	7	8
DL UNIT 1	366							0
DL UNIT 2		347						0
DL UNIT 8	-5	5						347
DL UNIT 3	1	1	347					0
DL UNIT 4		1	1	346				0
DL UNIT 5			1	3	345			0
DL UNIT 6					4	344		0
DL UNIT 7					-1	8	341	0

TABLE 5.12 - ACCUMULATED HANGER FORCE FOR DEAD LOAD STAGING  
(KIPS)

Hanger Loc ->	1	2	3	4	5	6	7	8
DL TOTAL UN1	366							0
DL TOTAL UN2	366	347						0
DL TOTAL UN8	361	352						347
DL TOTAL UN3	362	353	347					347
DL TOTAL UN4	362	354	348	346				347
DL TOTAL UN5	362	354	349	349	345			347
DL TOTAL UN6	362	354	349	349	349	344		347
DL TOTAL UN7	362	354	349	349	348	352	341	347

#### 5.4.3 Superimposed Dead Load

The hanger forces are nearly equal except for the one closest to the arch rib which is slightly less than the others because the bending stiffness of the tie beam transmits some of the load directly to the supports.

The superimposed dead load is different from the original design because the barriers were not considered in the superimposed dead load of the original design.

#### 5.4.4 Temperature

The results are equal for all but the first hanger. The force is a result of the arch attempting to lift upward. The upward movement is approximately proportional to the stiffness of the deck unit. The force in the first hanger is larger for the same reason that the first hanger force was smaller in the superimposed dead load case.

#### 5.4.5 Live Load

Live load was found to be controlled by lane load rather than vehicle load. The tributary area may be larger in the alternate deck than for the original design where the stress relief joints tend to limit the tributary area. Also, the tie beam in the original design was less rigid. However, the differences between the alternate and original designs are not large.



TABLE 5.13 - SUMMARY OF FORCES IN HANGERS  
(KIPS)

Hanger Loc ->	1	2	3	4	5	6	7	8
FINAL DL	362	354	349	349	348	352	341	347
Original	275	295	297	297	300	303	303	303
SIMP DL	74	90	93	93	93	92	92	92
Original	31	35	36	36	36	36	36	36
TEMPERATURE	10	7	7	7	7	7	7	7
LL+I(+)	61	72	74	74	74	74	75	75
Original	55	62	64	64	65	65	65	65
CASE I	699	733	735	735	733	737	725	733
CASE II	658	680	680	679	678	682	669	677

AREA = 6.9 SQ IN.

STRESS (KSI)

CASE I	101	106	106	106	106	107	105	106
CASE II	95	98	98	98	98	99	97	98

## 5.5 Dead Load Tie Cable and Reactions

### 5.5.1 General

The area of each pair of dead load tie cables is 72 inches square. They are used mainly to carry the thrust of the dead load of the structure. The axial stiffness of the deck and tie beams are large compared to that of the cables. The tension due to live load is small in the tie cable.

Results are reported for each of the loadings. It is assumed that there is only a tensile force in the cable. It is assumed fully effective when the first deck unit is placed on the structure. This can be accomplished only if it is supported and tightened under the dead load of the arch rib. Support is supplied by the hanger cables. Thus its full modulus is assumed in all analyses.

The results are presented in Table 5.14.

### 5.5.2 Staging of the Deck Units

The individual and accumulated results are reported for each stage of loading. The results are linear and additive in the dead load tie cable and reactions.

### 5.5.3 Superimposed Dead Load

Superimposed dead load thrust is carried by both the tie cable and the deck units. However the concrete is assumed to be only one-third as stiff as for the live load and temperature analyses. The reaction indicates that the alternate design is slightly heavier than the original design.

### 5.5.4 Temperature

The assumption for this load caused the arch and tie cable to become longer. This caused a reduction in the dead load force in the tie cable. This load is shown as an increase in the tensile force in the deck and as increased bending moment in the arch ribs. The temperature difference of 100 degrees Fahrenheit was rather arbitrary, but not unreasonable. Lengthening of the hangers also occurred due to the temperature change. This had a tendency to moderate the uplift on the deck due to the raising of the arch ribs.

### 5.5.5 Live Load

Live load causes maximum thrust in the tie cable when the thrust in the arch ribs are maximum and positive moment in the arch is maximum. There is no live load that can cause a reduction in the cable tension. Cable thrust is also maximum when the reaction is maximum. Thus, the same live loading is applied for each response. It is interesting to note that the ratio of cable thrust to reaction force is greater for superimposed dead load than for live load. The reason for this is that the tensile stiffness of the concrete in the deck units is greater for live load than for superimposed dead load. Thus, the deck is assigned a larger portion of the live load than it is for the superimposed dead load.

It is interesting to note that the reaction is the same as in the original design.



TABLE 5.14 - REACTIONS DUE TO STAGING OF DECK UNITS  
(KIPS)

Loading Seq ->	1	2	3	4	5	6	7	8
unit ->	un1	un2	un8	un3	un4	un5	un6	un7
DETAIL	-541	-348	-348	-348	-348	-348	-348	-348
ACCUMULATED	-541	-889	-1237	-1585	-1933	-2281	-2629	-2977

Force in the Dead Load Tie Cable Due to Staging of Deck Units  
(Kips)

Loading Seq ->	1	2	3	4	5	6	7	8
unit ->	un1	un2	un8	un3	un4	un5	un6	un7
DETAIL	143	252	674	364	463	547	614	662
ACCUMULATED	143	395	1069	1433	1896	2443	3057	3719

Summary of Reactions and Tie Cable Thrust  
(Kips)

	---DEAD LOAD---			TEMP	LL+I	----SERVICE----		---STRENGTH---	
	ARCH	STG	SIMP			CASE I	CASE II	CASE I	CASE II
REACTION	376	2977	718	-	595	4666	4666	6581	6066
Original	Total = 3335				594	3929	3929	5625	5625
TIE CABLE	452	3719	168	-1248	87	4426	3178	5829	4131
Tie cable stress (ksi)						61.5	44.2	81.0	57.4

## 5.6 Tie Beam

### 5.6.1 General

The tie beam results are reported in terms of stresses in the bottom of the web. Finite element stresses are computed at only the center of elements, thus it is necessary to modify the results to obtain values at nodes. Results are reported at both the maximum positive moment area midway between hangers and at maximum negative moment at the hangers. Results are reported for Design 1 at each location as described in Section 4 in Table 5.15.

The dead load results were recomputed by hand. The values for the tie beam are not compared to the original design values because the dead load tie cable causes significant differences in behavior in the alternate design compared to the original.

Complete results for Design 2 are reported in Tables 5.16 and 5.17.

#### 5.6.2 Dead Load

The stress for maximum and positive dead load moment was computed using the model shown in figure 5.8.

#### 5.6.3 Temperature

Stresses in the bottom of the tie beam web at the hanger are reported as the average of the stresses in the two elements on each side of that hanger. Results in the center element between hangers was used for the center location.

Most of the tie beam is in tension. However, it is of interest to note that the beam undergoes compression in the center of the span. This is caused in part by the arch rib lifting the tie beam enough to overcome the tension due to thrust. Since the arch is more vertical near the ends of the span, its thermal expansion gives a upward bend near the ends which introduces a positive moment in the tie beam. This produces a tensile stress in the bottom which is additive to the thrust stress. In the center of the span the negative bending moment produces compression in the bottom that overcomes the tensile stress due to thrust. The hanger forces are equal except for the first hanger from the support.

#### 5.5 Superimposed Dead Load

Superimposed dead load, like the thermal loading, mainly applies tensile force in the tie beam. At no location is there a compressive stress reported in the bottom of the tie beam. Stresses reported have been determined in the same manner as the thermal analysis.



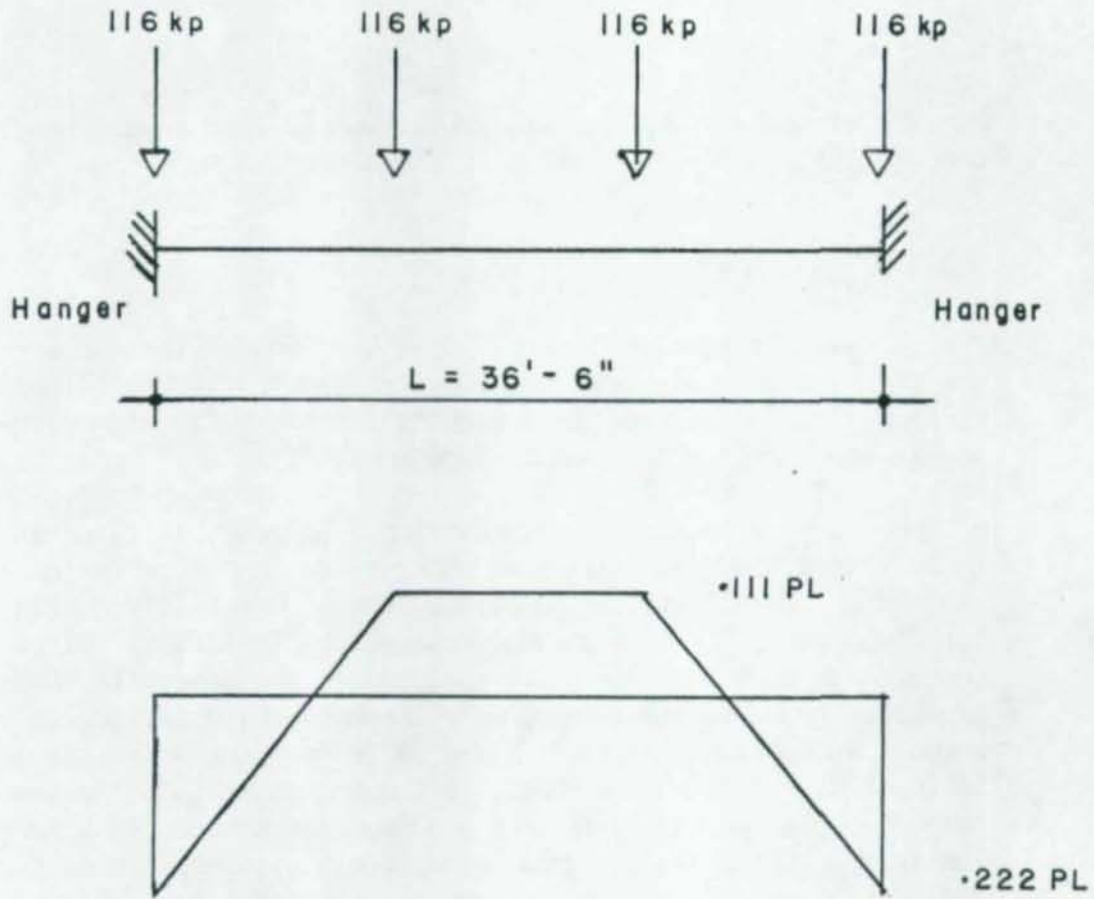

MOMENT DIAGRAM

DEAD LOAD MOMENT IN TIE BEAM

Fig 5.8

## 5.6 Live Load

Live load stresses are also reported at mid length of each element. Results are determined in the same manner as in the above two cases.

Floor beams not at hangers were not loaded in this study; therefore, the effect of bending in the tie beams due to local loads is not evident in the results. The moment due to this loading case is probably not significant since the span is only 36.5 feet and the beam depth is 9 feet. The small variation between element stresses between hangers indicates that local effects are negligible.

The results show a significant increase in tie beam bending toward the center of the span. The reason is that the tie beam is deflecting more there which increases the moment. In the second case the deck system was lighter and the moments in the tie beam became larger. Conversely, the heavier 24 inch deck resulted in much smaller tie beam stresses than those reported for the 15 inch deck.

TABLE 5.15 - TIE BEAM STRESSES BOTTOM OF WEB AT HANGERS  
FOR DESIGN 1  
(PSI)

Hanger Loc ->	0	1	2	3	4	5	6	7	8
DL	-205	-205	-205	-205	-205	-205	-205	-205	-205
SIMP DL	140	172	172	165	150	140	135	120	115
TEMPER	447	260	135	13	-90	-175	-235	-280	-302
LL+I TENS	520	583	836	1018	1092	1055	947	799	687
LL+I COMP	-379	-360	-576	-765	-836	-795	-669	-434	-364

TIE BEAM STRESSES AT BOTTOM OF WEB BETWEEN HANGERS  
FOR DESIGN 1  
(PSI)

Hanger Loc ->	0-1	1-2	2-3	3-4	4-5	5-6	6-7	7-8	8-9
DL	103	103	103	103	103	103	103	103	103
SIMP DL	200	225	210	192	179	169	157	159	157
TEMPER	315	201	74	-41	-135	-207	-260	-292	-304
LL+I TENS	440	680	1210	1098	1035	895	802	690	550
LL+I COMP	-613	-462	-790	-910	-816	-750	-602	-410	-322



TABLE 5.16 - TIE BEAM STRESSES BOTTOM OF WEB AT HANGERS  
FOR DESIGN 2  
(PSI)

Hanger Loc ->	0	1	2	3	4	5	6	7	8
DL	-189	-189	-189	-189	-189	-189	-189	-189	-189
SIMP DL	302	344	286	229	183	148	122	104	95
TEMPER	996	740	471	461	26	-138	-264	-351	-400
LL+I TENS	1211	1136	1590	1939	2077	2002	1757	1430	1193
LL+I COMP	-855	-777	-1130	-1553	-1728	-1676	-1441	-1092	-840

SERVICE LOAD

CASE I (+)	1324	1291	1687	1979	2071	1961	1690	1345	1099
CASE II (+)	2320	2031	2158	2440	2097	1823	1426	994	699

POST-TENSIONING

REGULAR	-2474	-2474	-2474	-2474	-2474	-2474	-2474	-2474	-2474
---------	-------	-------	-------	-------	-------	-------	-------	-------	-------

MAXIMUM COMPRESSION CHECK

SERVICE LOAD

CASE I (-)	-742	-622	-1033	-1513	-1734	-1717	-1508	-1177	-934
CASE II (-)	254	118	-562	-1052	-1708	-1855*	-1772	-1528	-1334

TEMPORARY	-2474	-1855 (HANGER 5)		= -4329	> 3200 PSI	NG			
	-2474 + 20%	-1855		= -4825	> 4400 PSI	NG			

$$\text{FACTORED POST TENSIONED STRESS} = 1.3 (-2474 + 20 \%) = -3859 \text{ KSI}$$

FACTORED

FACT P-T	-3859	-3859	-3859	-3859	-3859	-3859	-3859	-3859	-3859
CASE I (-)	-1705	-1482	-2322	-3312	-3752	-3684	-3210	-2477	-1942
CASE II (-)	330	154	-730	-1367	-2220	-2411	-2304	-1987	-1734
FINAL I	-4179	-3956	-4796	-5786	-6226	-6158	-5684	-4951	-4416
FINAL II	-2144	-2320	-3204	-3841	-4694	-4885	-4778	-4461	-4208
FINAL I	-5565	-5341	-6181	-7171	-7611*	-7543	-7069	-6337	-5801
FINAL II	-3529	-3706	-4590	-5226	-6080	-6270	-6163	-5846	-5594

$$\text{ALLOWABLE STRESS} = 8000 * .95 = 7600 \text{ PSI}$$

7611 exceeds 7600 psi NG

TABLE 5.17 - TIE BEAM STRESSES AT BOTTOM OF WEB BETWEEN HANGERS  
FOR DESIGN 2  
(PSI)

Hanger Loc ->	0-1	1-2	2-3	3-4	4-5	5-6	6-7	7-8	8-9
DL	94	94	94	94	94	94	94	94	94
SIMP DL	378	350	287	236	195	165	143	130	125
TEMPER	871	608	347	126	-60	-204	-310	-378	-409
LL+I TENS	1063	1338	1746	1999	2035	1865	1568	1249	1033
LL+I COMP	-713	-899	-1360	-1657	-1716	-1568	-1255	-929	-729

SERVICE LOAD

CASE I (+)	1535	1782	2127	2329	2324	2124	1805	1473	1252
CASE II (+)	2406	2390	2474*	2455	2264	1920	1495	1095	843

POST-TENSIONING

REGULAR	-2474	-2474	-2474	-2474	-2474	-2474	-2474	-2474	-2474
---------	-------	-------	-------	-------	-------	-------	-------	-------	-------

MAXIMUM COMPRESSION CHECK

SERVICE LOAD

CASE I (-)	-241	-455	-979	-1327	-1427	-1309	-1018	-705	-510
CASE II (-)	630	153	-632	-1201	-1487	-1513*	-1328	-1083	-919

TEMPORARY	-2474	-1513 (HANGER 5-6)	= -3987	> 3200 PSI	NG
	-2474 + 20%	-1513	= -4482	> 4400 PSI	NG

FACTORED POST TENSIONED STRESS = 1.3 (-2474 + 20 %) = -3859 KSI

FACTORED

FACT P-T	-3859	-3859	-3859	-3859	-3859	-3859	-3859	-3859	-3859
CASE I (-)	-930	-1370	-2451	-3162	-3343	-3060	-2411	-1721	-1294
CASE II (-)	819	199	-822	-1562	-1933	-1966	-1727	-1408	-1194
FINAL I	-4790	-5230	-6311	-7021	-7202*	-6919	-6271	-5580	-5153
FINAL II	-3040	-3660	-4681	-5421	-5793	-5826	-5586	-5267	-5054

ALLOWABLE STRESS = 8000 \* .95 = 7600 PSI  
7202 psi less than 7600 psi OK



## 5.7 Deck

### 5.7.1 General

Deck stress results are needed to determine the amount of post tensioning steel required. All concrete is post tensioned to avoid tensile stress. Since the deck varies in thickness and the stress levels vary across the width of the bridge, it is necessary to examine deck stresses in several locations across the width and along the length of the span. Some loads enter the deck from the arch rib and must be transferred into the entire deck through shear action. Local effects are not a function of shear lag.

Total stress in the deck is a combination of overall thrust from the arch rib; overall bending in the deck units due to flexibility of the arch ribs; local bending between floor beams; and to some degree bending between hangers.

Stresses on both top and bottom of the deck were recorded along the three lines "A", "B", and "C" shown in Figure 5.9. Since only stresses in the center of each element length are obtained, cusps near hangers are not observed directly from the results. Live load influence surfaces were not developed to examine local effects in the deck. Computation of local stresses is presented in section 5.7.2.

Post tensioning forces computed in the Tables are dealt with in subsequent sections.

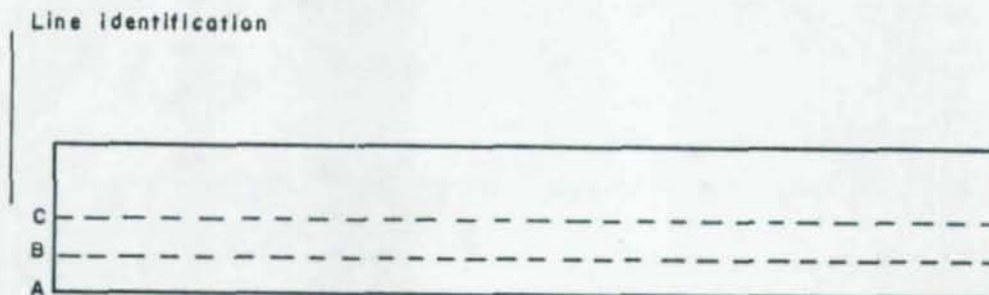

LOCATION OF RECORDED DECK STRESSES

Fig 5.9

## 5.7.2 Local Effects

The local bending due to live and dead loads is computed:

$$\text{Continuous Span} = 12'-2'' = 12.17 \text{ ft}$$

Dead Load Moment:

$$\text{Deck Thickness} = 9.0 \text{ in.}$$

$$\text{Density Concrete} = 0.150 \text{ k/cuft}$$

$$\text{Future Wearing Surface} = 0.030 \text{ ksf}$$

$$W = 0.150(0.75) + 0.030 = 0.142 \text{ k/ft}$$

$$\text{Dead Load Moment} = \frac{1}{12} WL = \frac{1}{12} (0.142)(12.17)(12.17) = 1.75 \text{ K-ft}$$

HS20 Live Load Moment = 0.900L K-ft for simple span AASHTO 3.2.33 (For Continuous Span Use 80 percent of the simple span value).

$$M = (0.80)(0.900)(12.17) = 8.76 \text{ K-ft}$$

Section Modulus of Deck

$$I = \frac{1}{12} bt^3 = \frac{1}{12} (1)(0.75)^3 = 0.0351 \text{ ft}^4$$

$$S = I/(t/2) = 0.0351/0.375 = 0.09375 \text{ ft}^3$$

Dead Load Stress

$$f = M/S = 1.75/0.09375 = 18.66 \text{ ksf} = 130 \text{ psi}$$

Live Load Stress including 30 percent impact

$$f = 1.30(8.76/0.09375) = 121.50 \text{ ksf} = 844 \text{ psi}$$

$$\text{Total Local Deck Stress} = 130 + 844 = 974 \text{ psi}$$

For deck thickness = 1.25 ft:

$$W = 0.150(1.25) + 0.030 = 0.2175 \text{ k/ft}$$

$$I = \frac{1}{6} bt^3 = \frac{1}{6} (1.0)(1.25)^3 = 0.260 \text{ ft}^4$$

$$\text{Dead Load Moment} = \frac{1}{12} WL = \frac{1}{12} (0.2175)(12.17) = 2.68 \text{ K-ft}$$

$$\text{Dead Load Stress} = 2.68/0.260 = 10.32 \text{ ksf} = 72 \text{ psi}$$

$$f \text{ Live Load} = 1.30(8.76/0.260) = 43.80 \text{ ksf} = 304 \text{ psi}$$

$$\text{Total Local Deck Stress} = 72 + 304 = 376 \text{ psi}$$



Deck stresses are reported in Tables 5.18 through 5.23. The discussion below relates to these tables. The tables are broken into two parts so that the locations at the hangers and between the hangers may be reported clearly. The temperature and superimposed runs were not observed to be different enough to warrant the use of different values in positive and negative moment areas of the deck.

The results for superimposed dead load and temperature runs are shown in Figures 5.10, 5.11 and 5.12. Stresses are plotted for the entire bridge width for each condition. In each figure there is a plot of the stress at the end of the span, the quarter-point and the mid-point of the span. Figures 5.10 and 5.11 show stresses in the top of the deck for Design 1 and 2, respectively. Figure 5.12 shows stress levels in the bottom of the deck for Design 2.

#### 5.7.3 Dead Load

Dead load stress due to the weight of the units is computed as if the structure was completed before the dead load was placed on the structure. The deck is not affected by thrust or overall bending due to its own weight since the dead load tie cable carries thrust from the arch rib and the deck units are not attached to the arch ribs at that time.

#### 5.7.4 Superimposed Dead Load

Superimposed dead load is applied after the deck units have become part of the integrated structure. It may be thought of as having two components; the thrust and the local bending. The stresses reported are results of the center element between hangers. The one exception is the stress at the arch rib. This value is the stress in the element closest to the arch. The center element is used because it is at the maximum positive moment location with respect to local bending. All values represent a combination of the two components; thrust and local effects.

The results show clearly that the thrust is the dominate component. At the end of the span, the stress is highest where the thrust enters the deck. In the middle of the deck, the stress is small. At the quarter point and at mid-span the stress is much lower in Line "A" than at the other locations. This is due to the thicker deck at these points. Shear has distributed the thrust rather uniformly over the deck by the quarter-point.

STRESS AT TOP OF DECK DUE TO SDL AND TEMPERATURE

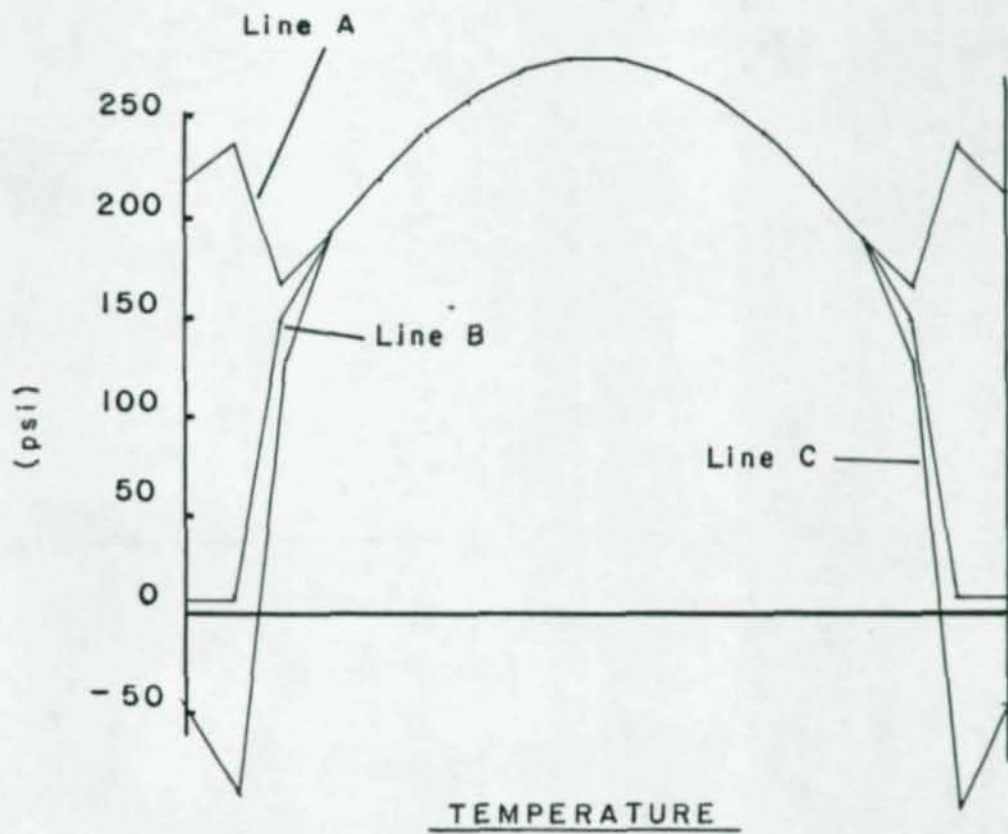
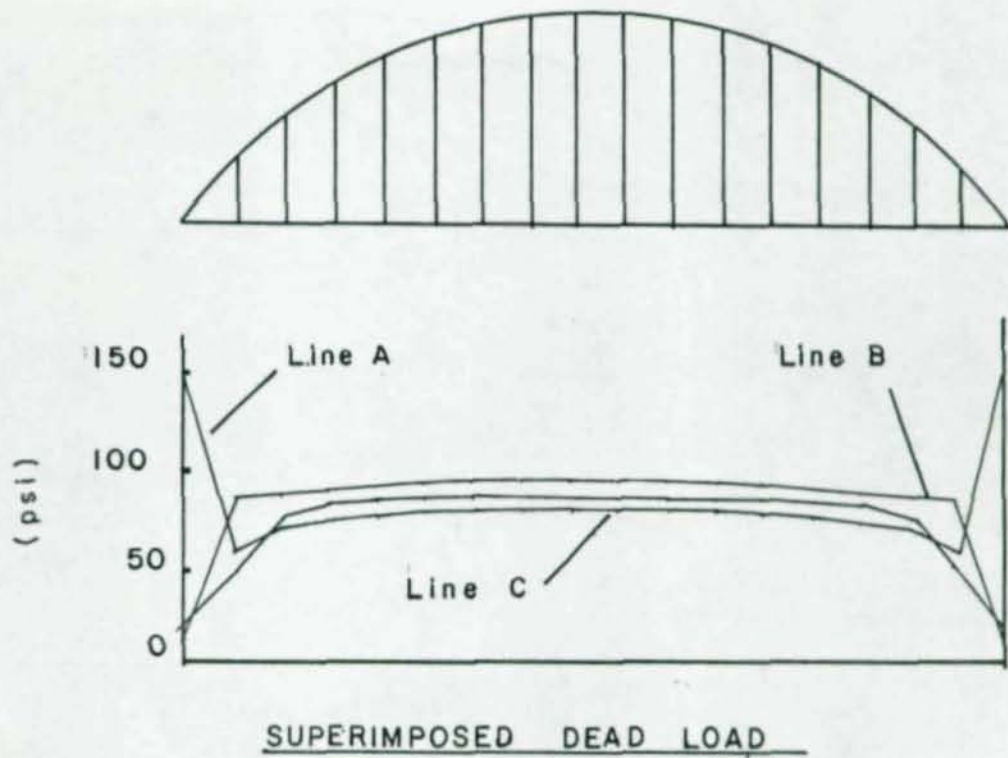

Fig 5.10



## STRESS AT TOP OF DECK DUE TO SDL AND TEMPERATURE

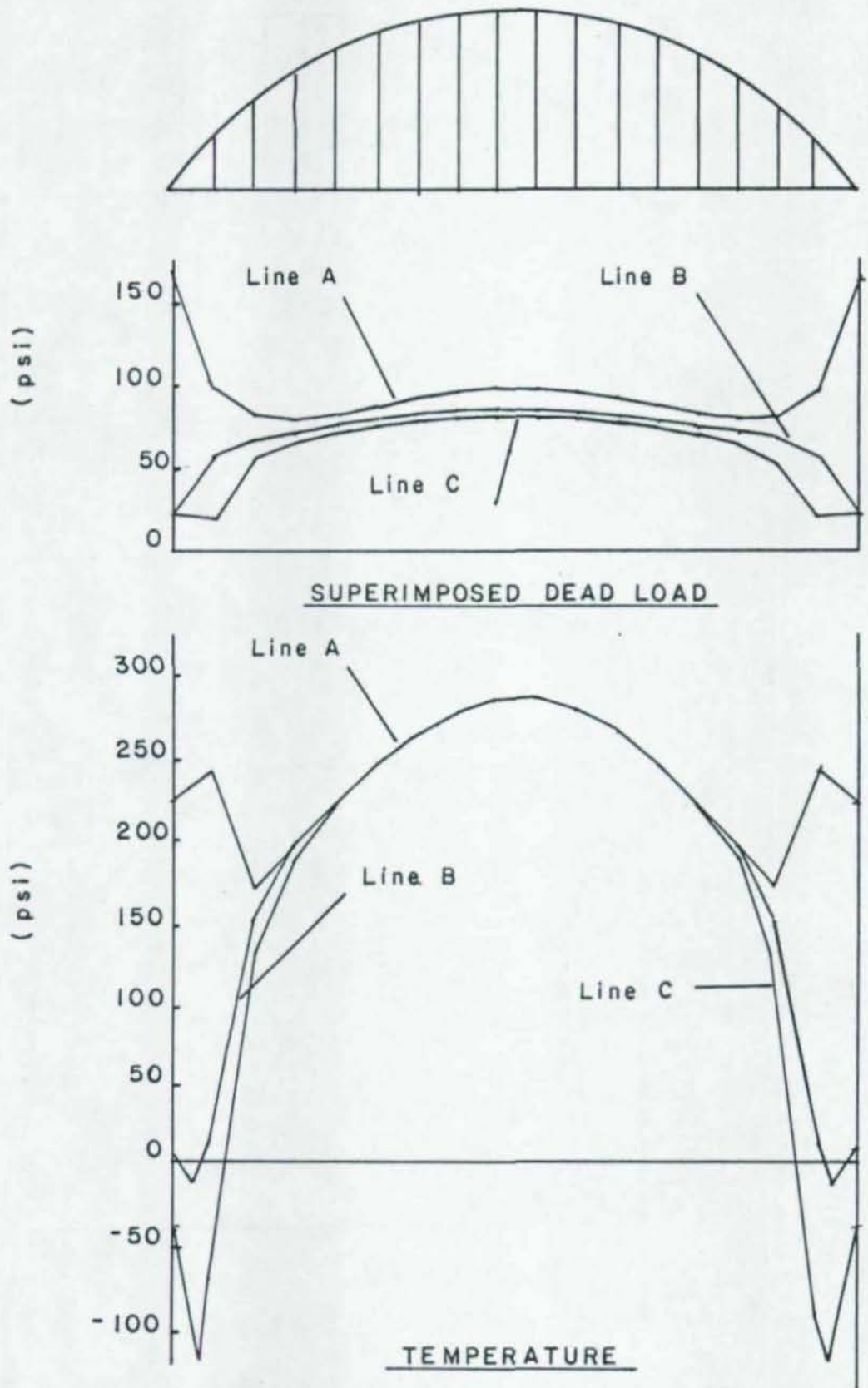

Fig 5.11

STRESS AT BOTTOM OF DECK DUE TO SDL AND TEMPERATURE

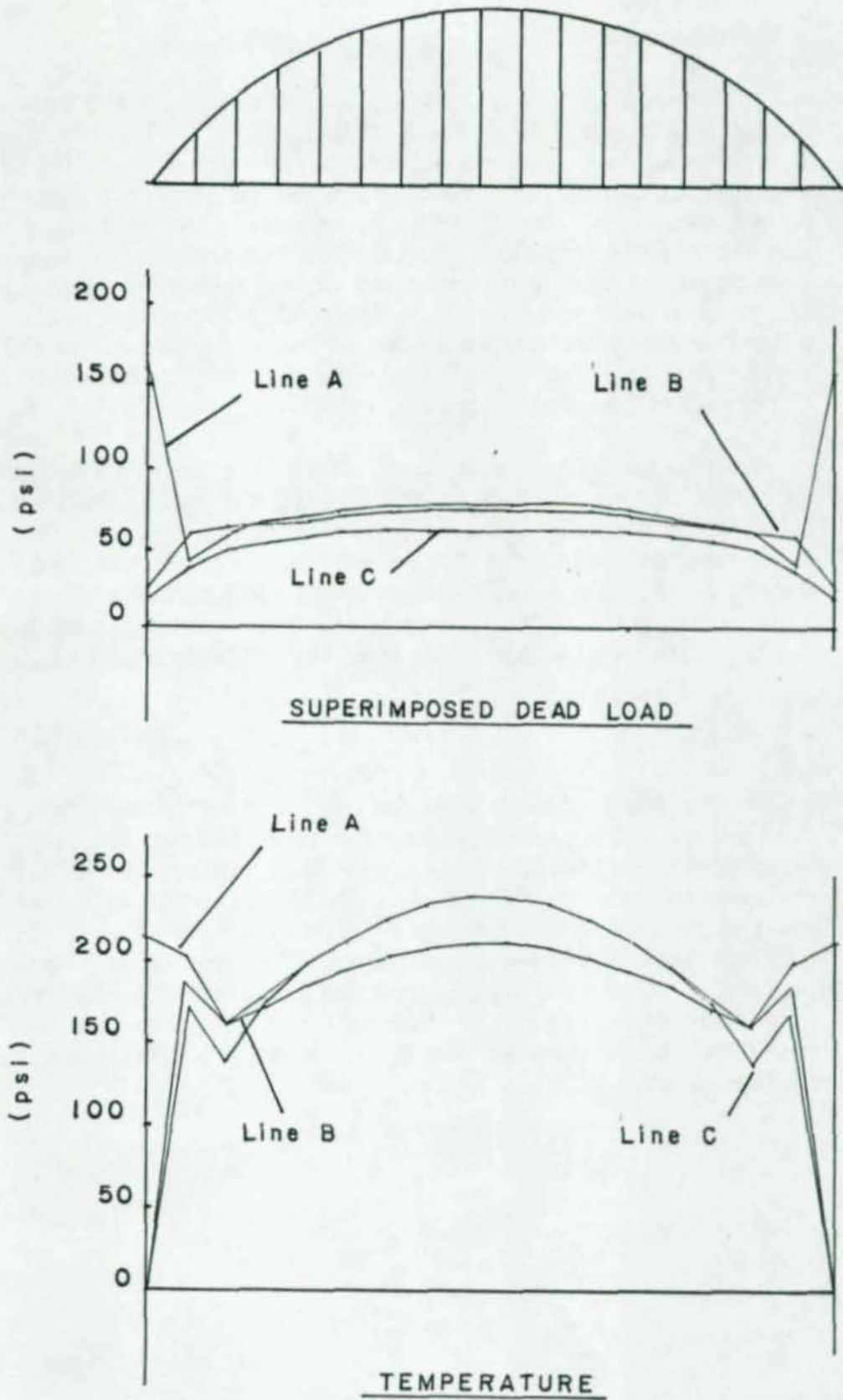

Fig 5.12



### 5.7.5 Temperature

The results for this analysis were obtained in the same manner as for superimposed dead load. This run did not produce observable variation in deck stresses between hangers since there were no vertical loads applied. Temperature has two apparent effects on the deck: The arch is attempting to lift the deck upward; and the arch is attempting to lengthen the deck due to expansion both longitudinally and vertically of the arch ribs and lengthening of the dead load tie cable. In the analysis, the tie cable actually pulled on the deck whereas is the actual structure, it would amount to a transfer of the dead load thrust from the cable to the deck and tie beam units.

As in superimposed dead load, there is a large difference in stress across the deck at the ends of the span. This occurs because the force in the deck is introduced by the arch rib and dead load tie cable. In fact, shear lag is so severe that the center of the deck reverses sign to maintain equilibrium. At the quarter point of the span tensile force is equal across the bridge width and remains equal over the center portion.

### 5.7.6 Live Load

The local effects were computed by hand as was local dead load stress. The overall stresses were determined from the loader which positions the live load to produce maximum and minimum stresses in each element investigated. The reported values are the average of the two elements on each side of a hanger. The influences surfaces are produced by loading only positions over floor beams at hangers, thus the local effects of bending over floor beams are not evident in these results. The hand calculated local stresses are added to the stresses determined by the loader.

TABLE 5.18 - DECK STRESSES TOP LINE "A"  
(PSI)

Hanger Loc ->	0	1	2	3	4	5	6	7	8
SIMP DL	152	63	72	73	77	78	80	80	80
TEMPERATURE	217	236	167	190	220	243	260	272	277
LL+I TENS	242	352	458	551	580	570	508	410	309
LL+I COMP	-68	-299	-453	-555	-590	-565	-492	-391	-299
SERVICE LOAD WITHOUT LOCAL									
CASE I (+)	394	415	530	624	657*	648	588	490	389
CASE II (+)	611	651	697	814	877	891*	848	762	666
SERVICE LOAD LOCAL									
DL LOCAL (+)	72	72	72	72	72	72	72	72	72
LL+I LOCAL (+)	304	304	304	304	304	304	304	304	304
SERVICE									
CASE I & II	376	376	376	376	376	376	376	376	376
POST-TENSIONING REQUIRED FOR LOCAL BENDING CASE II									
REGULAR	-891	-891	-891	-891	-891	-891	-891	-891	-891
LOCAL	-376	-376	-376	-376	-376	-376	-376	-376	-376
TOTAL	-1267	-1267	-1267	-1267	-1267	-1267	-1267	-1267	-1267
MAXIMUM COMPRESSION CHECK									
SERVICE LOAD WITHOUT LOCAL									
CASE I (-)	84	-236	-381	-482	-513*	-487	-412	-311	-219
CASE II (-)	301	0	-214	-292	-293*	-244	-152	-39	58
Case I	-1033	-293	(HANGER 4)	=	-1326	<	3200	PSI	OK
TEMPORARY	-1033	+ 20%	-513	=	-1753	<	4400	PSI	OK
Case II	-1267	-293	(HANGER 5)	=	-1560	<	4000	PSI	OK
TEMPORARY	-1267	+ 20%	-293	=	-1813	<	5500	PSI	OK
FACTORED POST TENSIONED VALUE = 1.3 (-1267*1.20) = -1977									
STRENGTH CHECK									
FACT P-T	-1977	-1977	-1977	-1977	-1977	-1977	-1977	-1977	-1977
CASE I (-)	50	-566	-889	-1108	-1178	-1122	-963	-743	-544
CASE II (-)	391	0	-279	-380	-381	-317	-198	-51	75
(LOCAL)									
CASE I	-753	-753	-753	-753	-753	-753	-753	-753	-753
CASE II	-489	-489	-489	-489	-489	-489	-489	-489	-489
FINAL I	-2680	-3296	-3618	-3837	-3907	-3852	-3692	-3472	-3273
FINAL II	-2075	-2466	-2745	-2846	-2847	-2783	-2664	-2516	-2391



TABLE 5.19 - DECK STRESSES BOTTOM LINE "A"  
(PSI)

Hanger Loc ->	0-1	1-2	2-3	3-4	4-5	5-6	6-7	7-8	8-9
SIMP DL	162	41	49	52	56	59	61	63	63
TEMPERATURE	217	205	165	177	199	214	226	234	238
LL+I TENS	223	305	387	453	483	467	426	352	266
LL+I COMP	-39	-250	-367	-440	-463	-440	-387	-309	-232
SERVICE LOAD (NO LOCAL)									
CASE I (+)	385	346	436	505	539	526	487	415	329
CASE II (+)	602	551	601	682	738	740	713	649	567
LOCAL BENDING									
DL LOCAL (+)	72	72	72	72	72	72	72	72	72
LL+I LOCAL (+)	304	304	304	304	304	304	304	304	304
SERVICE									
CASE I & II	376	376	376	376	376	376	376	376	376
POST-TENSIONING									
REGULAR	-891	-891	-891	-891	-891	-891	-891	-891	-891
LOCAL	-376	-376	-376	-376	-376	-376	-376	-376	-376
TOTAL	-1267	-1267	-1267	-1267	-1267	-1267	-1267	-1267	-1267
MAXIMUM COMPRESSION CHECK									
SERVICE LOAD (NO LOCAL)									
CASE I (-)	123	-209	-318	-388	-407*	-381	-326	-246	-169
CASE II (-)	340	-4	-153	-211*	-208	-167	-100	-12	69
Case I	-1033	-407	(HANGER 4)	=	-1440	<	3200	PSI	OK
TEMPORARY	-1033	+ 20%	-407	=	-1647	<	4400	PSI	OK
Case II	-1267	-211	(HANGER 5)	=	-1478	<	4000	PSI	OK
TEMPORARY	-1267	+ 20%	-211	=	-1731	<	5500	PSI	OK
FACTORED POST TENSIONED VALUE = 1.3 (-1267 + 20 %) = -1977									
FACTORED LOADS									
FACT P-T	-1977	-1977	-1977	-1977	-1977	-1977	-1977	-1977	-1977
CASE I (-)	126	-489	-732	-885	-931	-876	-759	-587	-421
CASE II (-)	442	-6	-199	-274	-271	-217	-130	-15	89
(LOCAL)									
CASE I	-753	-753	-753	-753	-753	-753	-753	-753	-753
CASE II	-489	-489	-489	-489	-489	-489	-489	-489	-489
FINAL I	-2603	-3219	-3461	-3614	-3660*	-3605	-3488	-3317	-3151
FINAL II	-2024	-2472	-2665	-2740	-2737	-2682	-2595	-2481	-2377

TABLE 5.20 - DECK STRESSES TOP LINE "B"  
(PSI)

Hanger Loc ->	0	1	2	3	4	5	6	7	8
SIMP DL	12	87	87	89	90	92	93	93	93
TEMPERATURE	7	8	149	191	219	242	259	270	276
LL+I TENS	58	203	334	401	426	406	357	285	223
LL+I COMP	-10	-246	-377	-453	-473	-453	-396	-319	-256
SERVICE LOAD (NO LOCAL)									
CASE I (+)	70	290	421	490	516	498	450	378	316
CASE II (+)	77	298	570	681	735	740*	709	648	592
LOCAL BENDING									
DL LOCAL (+)	130	130	130	130	130	130	130	130	130
LL+I LOCAL (+)	844	844	844	844	844	844	844	844	844
SERVICE									
CASE I & II	974	974	974	974	974	974	974	974	974
POST-TENSIONING									
REGULAR	-740	-740	-740	-740	-740	-740	-740	-740	-740
LOCAL	-974	-974	-974	-974	-974	-974	-974	-974	-974
TOTAL	-1714	-1714	-1714	-1714	-1714	-1714	-1714	-1714	-1714
MAXIMUM COMPRESSION CHECK									
SERVICE LOAD (NO LOCAL)									
CASE I (-)	2	-159	-290	-364	-383*	-361	-303	-226	-163
CASE II (-)	9	-151	-141	-173*	-164	-119	-44	44	113
Case I	-1714	-383	(HANGER 4)	=	-2097	<	3200	PSI	OK
TEMPORARY	-1714	+ 20%	-383	=	-2440	<	4400	PSI	OK
Case II	-1714	-173	(HANGER 5)	=	-1887	<	4000	PSI	OK
TEMPORARY	-1714	+ 20%	-173	=	-2230	<	5500	PSI	OK
FACTORED POST TENSIONED VALUE = 1.3 (-1714 + 20 %) = -2673									
FACTORED LOADS									
FACT P-T	-2673	-2673	-2673	-2673	-2673	-2673	-2673	-2673	-2673
CASE I (-)	-5	-420	-704	-867	-908	-863	-738	-569	-434
CASE II (-)	12	-197	-183	-226	-213	-155	-58	58	147
(LOCAL)									
CASE I	-1997	-1997	-1997	-1997	-1997	-1997	-1997	-1997	-1997
CASE II	-1266	-1266	-1266	-1266	-1266	-1266	-1266	-1266	-1266
FINAL I	-4676	-5091	-5374	-5537	-5578	-5533	-5408	-5240	-5104
FINAL II	-3927	-4136	-4122	-4165	-4152	-4094	-3997	-3881	-3792



TABLE 5.21 - DECK STRESSES BOTTOM LINE "B"  
(PSI)

Hanger Loc ->	0-1	1-2	2-3	3-4	4-5	5-6	6-7	7-8	8-9
SIMP DL	24	59	62	66	70	73	74	76	76
TEMPERATURE	-10	184	164	172	184	195	203	208	211
LL+I TENS	29	227	256	285	299	294	270	250	223
LL+I COMP	-63	-88	-154	-193	-207	-198	-164	-125	-92
SERVICE LOAD (NO LOCAL)									
CASE I (+)	53	286	318	351	369	367	344	326	299
CASE II (+)	43	470	482	523	553	562	547	534	510
LOCAL BENDING									
DL LOCAL (+)	130	130	130	130	130	130	130	130	130
LL+I LOCAL (+)	844	844	844	844	844	844	844	844	844
SERVICE									
CASE I & II	974	974	974	974	974	974	974	974	974
POST-TENSIONING									
REGULAR	-740	-740	-740	-740	-740	-740	-740	-740	-740
LOCAL	-974	-974	-974	-974	-974	-974	-974	-974	-974
TOTAL	-1714	-1714	-1714	-1714	-1714	-1714	-1714	-1714	-1714
MAXIMUM COMPRESSION CHECK									
SERVICE LOAD (NO LOCAL)									
CASE I (-)	-39	-29	-92	-127	-137*	-125	-90	-49	-16
CASE II (-)	-49*	155	72	45	47	70	113	159	195
Case I	-1714	-137	(HANGER 4)	=	-1851	<	3200	PSI	OK
TEMPORARY	-1714	+ 20%	-137	=	-2194	<	4400	PSI	OK
Case II	-1714	-49	(HANGER 5)	=	-1763	<	4000	PSI	OK
TEMPORARY	-1714	+ 20%	-49	=	-2106	<	5500	PSI	OK
FACTORED POST TENSIONED VALUE = 1.3 (-1714 + 20 %) = -2673									
FACTORED LOADS									
FACT P-T	-2673	-2673	-2673	-2673	-2673	-2673	-2673	-2673	-2673
CASE I (-)	-104	-113	-254	-333	-358	-333	-259	-172	-100
CASE II (-)	-63	202	93	58	61	92	147	206	254
(LOCAL)									
CASE I	-1997	-1997	-1997	-1997	-1997	-1997	-1997	-1997	-1997
CASE II	-1266	-1266	-1266	-1266	-1266	-1266	-1266	-1266	-1266
FINAL I	-4775	-4783	-4924	-5003	-5028	-5003	-4930	-4843	-4770
FINAL II	-4002	-3737	-3846	-3881	-3878	-3848	-3792	-3733	-3685

TABLE 5.22 - DECK STRESSES TOP LINE "C"  
(PSI)

Hanger Loc ->	0	1	2	3	4	5	6	7	8
SIMP DL	17	50	74	80	83	84	85	86	86
TEMPERATURE	-38	-89	130	188	218	241	257	269	275
LL+I TENS	78	96	193	252	270	256	217	164	131
LL+I COMP	-29	-242	-324	-381	-396	-371	-334	-280	-246
SERVICE LOAD (NO LOCAL)									
CASE I (+)	95	146	267	332	353	340	302	250	217
CASE II (+)	57	57	397	520	571	581	559	519	492
LOCAL BENDING									
DL LOCAL (+)	130	130	130	130	130	130	130	130	130
LL+I LOCAL (+)	844	844	844	844	844	844	844	844	844
SERVICE									
CASE I & II	974	974	974	974	974	974	974	974	974
POST-TENSIONING									
REGULAR	-615	-615	-615	-615	-615	-615	-615	-615	-615
LOCAL	-974	-974	-974	-974	-974	-974	-974	-974	-974
TOTAL	-1589	-1589	-1589	-1589	-1589	-1589	-1589	-1589	-1589
MAXIMUM COMPRESSION CHECK									
SERVICE LOAD (NO LOCAL)									
CASE I (-)	-12	-192	-250	-301	-313*	-287	-249	-194	-160
CASE II (-)	-50	-281*	-120	-113	-95	-46	8	75	115
Case I	-1589	-313	(HANGER 4) = -1902 < 3200 PSI OK						
TEMPORARY	-1589 + 20%	-313	= -2124 < 4400 PSI OK						
Case II	-1589	-281	(HANGER 5) = -1870 < 4000 PSI OK						
TEMPORARY	-1589 + 20%	-281	= -2188 < 5500 PSI OK						
FACTORED POST TENSIONED VALUE = 1.3 (-1589 + 20 %) = -2478									
FACTORED LOADS									
FACT P-T	-2478	-2478	-2478	-2478	-2478	-2478	-2478	-2478	-2478
CASE I (-)	-41	-459	-606	-722	-751	-695	-613	-494	-422
CASE II (-)	-65	-365	-156	-147	-124	-60	11	98	149
(LOCAL)									
CASE I	-1997	-1997	-1997	-1997	-1997	-1997	-1997	-1997	-1997
CASE II	-1266	-1266	-1266	-1266	-1266	-1266	-1266	-1266	-1266
FINAL I	-4517	-4935	-5081	-5197	-5226	-5171	-5088	-4969	-4897
FINAL II	-3809	-4110	-3900	-3891	-3868	-3804	-3734	-3646	-3595



TABLE 5.23 - DECK STRESSES BOTTOM LINE "C"  
(PSI)

Hanger Loc ->	0-1	1-2	2-3	3-4	4-5	5-6	6-7	7-8	8-9
SIMP DL	19	38	60	68	73	75	77	78	78
TEMPERATURE	-5	170	136	175	197	212	224	232	235
LL+I TENS	19	270	299	319	328	328	314	295	280
LL+I COMP	-58	-92	-159	-207	-217	-202	-174	-140	-121
SERVICE LOAD (NO LOCAL)									
CASE I (+)	38	308	359	387	401	403	391	373	358
CASE II (+)	33	478	495	562	598	615*	615*	605	593
LOCAL BENDING									
DL LOCAL (+)	130	130	130	130	130	130	130	130	130
LL+I LOCAL (+)	844	844	844	844	844	844	844	844	844
SERVICE									
CASE I & II	974	974	974	974	974	974	974	974	974
POST-TENSIONING									
REGULAR	-615	-615	-615	-615	-615	-615	-615	-615	-615
LOCAL	-974	-974	-974	-974	-974	-974	-974	-974	-974
TOTAL	-1589	-1589	-1589	-1589	-1589	-1589	-1589	-1589	-1589
MAXIMUM COMPRESSION CHECK									
SERVICE LOAD (NO LOCAL)									
CASE I (-)	-39	-54	-99	-139	-144*	-127	-97	-62	-43
CASE II (-)	-44*	116	37	36	53	85	127	170	192
Case I	-1589	-144	(HANGER 4)	=	-1733	<	3200	PSI	OK
TEMPORARY	-1589	+ 20%	-144	=	-2051	<	4400	PSI	OK
Case II	-1589	-44	(HANGER 5)	=	-1633	<	4000	PSI	OK
TEMPORARY	-1589	+ 20%	-44	=	-1951	<	5500	PSI	OK
FACTORED POST TENSIONED VALUE = 1.3 (-1589 + 20 %) = -2478									
FACTORED LOADS									
FACT P-T	-2478	-2478	-2478	-2478	-2478	-2478	-2478	-2478	-2478
CASE I (-)	-102	-150	-266	-361	-375	-339	-277	-203	-161
CASE II (-)	-58	151	49	46	69	111	165	220	250
(LOCAL)									
CASE I	-1998	-1998	-1998	-1998	-1998	-1998	-1998	-1998	-1998
CASE II	-1266	-1266	-1266	-1266	-1266	-1266	-1266	-1266	-1266
FINAL I	-4578	-4626	-4742	-4837	-4852	-4816	-4753	-4679	-4637
FINAL II	-3803	-3594	-3696	-3699	-3676	-3634	-3580	-3525	-3495

## 5.8 Post Tensioning Computations

### 5.8.1 General

Design of post tensioning is based on Section 8 of the AASHTO Bridge Specification. It is assumed that no creep or shrinkage have been removed from the units prior to tensioning. This is a conservative assumption with regard to a large bridge.

CASE I includes dead and live loads. CASE II includes dead, live and temperature loads. All allowable stresses for CASE II are increased to 125 percent of the allowable according to AASHTO Table 3.22.1A. (Ref.5).

Post tensioning is designed for local bending in the deck. Local bending includes dead and live load moments computed by assuming that floor beams are rigid. This strand is draped to follow the local moment envelope. Post tensioning applies maximum compression where the local bending produces tensile stress. On the other side of the deck, the same post tensioning produces no compression. Thus, the local compression does not have to be added to its post tensioning stress when checking for crushing.

Overall stress in the deck due to thrust and bending of the entire deck unit is assumed to be constant across the deck when designing post tensioning to resist it. The maximum value from either the top or bottom is used. This post tensioning is positioned in the center of the deck.

Strand in the bottom flange of the tie beam is designed based on tension and compression in bottom of the web element. It is assumed constant over the entire span as is post tensioning stress in the deck. There is no design presented for strand in the web.

The following parameters are used in designing post tensioning:

#### Concrete -

$f_c' = 8000$  psi  
Density = 150 pcf  
Young's Modulus = 5700 ksi  
Allowable strand anchorage = 3000 psi.

#### Post Tensioning Steel -

Ultimate strength = 270 ksi  
Yield Stress = 216 ksi  
Young's Modulus = 28000 ksi



## 5.8.2 Deck

Post tensioning in the deck is divided into two parts. One part is used to post tension the deck for local bending stresses due to dead and live load. The second part is used to post tension for overall tension forces in the deck. Overall forces are due to superimposed dead load, temperature and live loads. Post tensioning for local moments is placed eccentrically one sixth the depth of the deck toward the tensile stress. At floor beams the local bending moment is negative so the strand would be located  $t/6$  above the center of gravity of the deck. By putting strand at this location, a compressive stress is induced on one side equal to  $(2t/9) \times \text{Force}$ . The other side has zero compression. The remaining strand is placed at the center of the deck.

The compressive strength of the deck may not be exceeded at the time of post tensioning. This limit is based on a  $\phi$  factor = 0.95 and load factors appropriate factors plus post tensioning stress with a load factor of 1.3. Allowable tensile stress is zero.

Allowable stress of  $0.55f_c'$  for the unfactored loads must not be exceeded prior to losses in post tensioning. This includes the sum of any combination of local and overall stresses and post tensioning forces.

The allowable stress of  $0.4f_c'$  for unfactored loads must not be exceeded after losses have occurred.

No tension may occur in concrete under any combination of loads. This is simply to insure that the joints do not open.

Strand stress shall not exceed  $0.7 \times$  ultimate strength of the strand when it is installed.

Strand must not exceed  $0.8 \times$  yield of the strand under permanent loads after losses.

Loss of post tensioning shall include consideration for the following factors:

- Shrinkage - SH
- Creep of Concrete - CRC
- Creep of Steel - CRS
- Elastic shortening ES

In addition, friction losses in strand ducts shall be considered.

## Steel Allowables

Post tensioning must overcome all tension stresses in the concrete without failing the concrete in the compression region. AASHTO-Section 9 is used to check allowable stresses.

## Assumptions:

Para. 9.13.2.1 Strains vary linearly over depth of section.

Para. 9.14 Phi = 1.0 for factory produced concrete.

Para. 9.15.1 Temporary stress before losses due to creep and shrinkage =  $0.70 * \text{strength of prestress steel}$

$$0.70 * 270000 = 189000 \text{ psi}$$

Stress at service load =  $0.80 * \text{yield strength of post tensioning steel.}$

$$= 0.80 * 216000 = 172800 \text{ psi}$$

Para 9.15.2.1 Post tens conc (Before losses) =  $0.55 * \text{strength}$

$$= 0.55 * 8000 = 4400 \text{ psi}$$

Para 9.51.2.2 Stress at service load

$$\text{Comp.} = 0.40 * \text{strength} = 0.40 * 8000 = 3200 \text{ psi}$$

$$\text{Tension} = 6 * (\text{strength}) * 0.5$$

$$\text{bonded reinf. case} = 6(8000) * 0.5 = 537 \text{ psi}$$

Para 9.15.2.4 Anchorage = 3000 psi

Para. 9.16.1 Friction loss

$$\text{Wire galva. metal sheathing} = 0.0002 \text{ K/ft}$$

$$T_o = T_x(1 + KL)$$

$$L = \text{Span}/2 \text{ Because jacking will occur from both ends.}$$

$$T_o = T_x(1 + 0.0002 * 310) = T_x(1.062)$$

Para. 9.16.2.1

$$\text{SH shrinkage} = 0.80(17000 - 150RH)$$

$$= 0.80(17000 - 150 * 70) = 5200 \text{ psi}$$

$$\text{ES elast. short.} = 0.5(E_s/E_{ci}) * f_{cir}$$

$$= 0.5(28/5.4) * 1589 = 3896 \text{ psi}$$



## Concrete Creep

$$CRc = 12 * fcir - 7 * fc ds$$

$fcir$  = concrete stress at the center of gravity of the prestressing steel due to prestressing force and dead load of beam immediately after transfer;  $fcir$  shall be computed at the section or sections of maximum moment. (At this stage, the initial stress in the tendon has been reduced by elastic shortening of the concrete and tendon friction for post-tensioning members. The reductions to initial tendon stress due to these factors can be estimated, or the reduced tendon stress can be taken as  $0.63f's'$  for typical pretensioned members.)

$$CRc = 12 * 1500 - 7 * 0 = 18000$$

## Creep of Steel

$$\begin{aligned} CRs &= 20000 - 0.3FR - 0.4ES - 0.2(SH + CRc) \\ &\text{for 270 ksi strand} \\ &= 20000 - 0.3(10714) - 0.4(3896) - 0.2(5200 + 18000) \\ &= 10587 \text{ psi} \end{aligned}$$

## Para. 9.17.4

## Allow. Steel Stress in Bonded members

$$\begin{aligned} fsu^* &= f's * (1 - 0.5(p*f's/f'c)) \\ &\text{effective prestress after loss not less than } 0.5f's \\ &\text{say } p^* = 0.005 \text{ or } 1/2 \text{ percent} \\ fsu^* &= 270000(1 - 0.5(0.005 * 270000 / 8000)) = 247219 \text{ psi} \end{aligned}$$

## Total loss equals:

$$\begin{array}{rcccccc} SH & + & ES & + & CRc & + & CRs \\ 5200 & + & 3896 & + & 18000 & + & 10714 = 37810 \text{ psi} \end{array}$$

$$\text{Percent Loss} = 37810 / 189000 = 20 \text{ percent}$$

Friction 0.062

Design of post tensioning in deck  
-----

Phi = 0.95; Strength = 7600 psi

Strength  
-----

CASE I  $0.95 \cdot 8000 > 1.3(DL + 5/3(LL+I))$

CASE II  $0.95 \cdot 8000 > 1.3(DL + T + (LL+I))$

Steel  $0.95 \cdot 270000 = 256500$  psi

Service  
-----

Percent loss = Estimated at 20%

Before losses  
-----

CASE I

Concrete

Compression

$0.55 \cdot 8000 = 4400 > DL + (LL+I) + \text{Post tension} \cdot 1.20$

Tension = 0.0

CASE II

Concrete

Compression

$0.55 \cdot 8000 \cdot 1.25 = 5500 > DL + (LL+I) + T + \text{Post tension} \cdot 1.20$

Tension = 0.0

Steel  $0.7 \cdot 270000 = 189000$  psi before losses

After Losses  
-----

Concrete

CASE I Compression  $0.40 \cdot 8000 = 3200 > DL + (LL+I) + \text{Post tension}$

CASE II  $0.40 \cdot 8000 \cdot 1.25 = 4000 > DL + (LL+I) + T + \text{Post tension}$

Steel  $0.8 \cdot 216000 = 172800$  psi after losses



Determine the level of stress permitted in the strand before losses.

Final stress must be less than 172800 psi.

Loss of prestress in steel = 37810 psi.

Before loss limit =  $172800 + 37810 = 210610$  psi

Absolute limit = 189000 psi

Since  $210190 > 189000$ , limit = 189000 psi

Stress in strand after losses =  $189000 - 37801$   
= 151199 psi

Area of 1-270 ksi 1/2" dia strand = 0.153 in<sup>2</sup>

Line "A" t = 15"  
-----

Local bending stress = 376 psi top and bottom.

Position strand at  $15/6 = 2.5$  " above center of deck.

Allowable stress in steel = 151199 psi Area one 1/2" dia  
strand = 0.153 in<sup>2</sup>

Stress due to post tensioning placed at 1/6 deck thickness from center of gravity on side of tension stress. This strand is to be draped to match local bending moments.

$$f = 2F/t$$

$$F \text{ required} = (t/2)*f = 15/2*(376) = 2820 \text{ pounds/inch}$$

$$\text{or } 2820 * 12 = 33840 \text{ pounds/ft}$$

$$\text{No. strand reqd} = 33840/(0.153*151199) = 1.45$$

Adjust for 6.2% friction loss.

$$1.45 * 1.062 = 1.54$$

Say 1.5 strand/ft.

Strand for axial forces in deck

Critical case - After losses = 1267 psi (CASE II)

to avoid any tension in deck.

$$\text{No. strand} = 1267*15*12/(0.153*151199) = 10.06$$

Adjust for 6.2% friction.

$$10.06 * 1.062 = 10.68$$

= Say 11 strand/ft

-----

Line "B"  $t = 9"$   
-----

Local bending stress = 974 psi top and bottom.  
Position strand at  $9/6 = 1.5"$  above center of deck.  
Allowable stress in steel = 151199 psi  
Area = 0.153 in<sup>2</sup>

Stress due to post tensioning placed at  $1/6$  deck thickness from center of gravity on side of tension stress. This strand to be draped to match local bending moments.

$$f = 2F/t$$

$$F \text{ required} = (t/2)*f = 9/2*(974) = 4383 \text{ pounds/inch}$$

$$\text{or } 4383 * 12 = 52596 \text{ pounds/ft}$$

$$\text{No. strand reqd} = 52596 / (0.153 * 151199) = 2.3$$

Adjust for 6.2% friction.

$$2.3 * 1.062 = 2.4; \text{ Say } = 2.5 \text{ strand/ft}$$

Strand for axial forces in deck

Critical stress after losses = 1714 psi (CASE II)

$$\text{No. strand} = 1714 * 9 * 12 / (0.153 * 151199) = 7.98$$

Adjust for 6.2% friction.

$$7.98 * 1.062 = 8.47$$

$$= \text{ Say } 8.5 \text{ strand/ft}$$

-----  
Line "C"

Since line "C" is nearly the same as line "B", make the same.  
-----

Total strand weight in deck

Line	Local	Overall	Total
A	1.5	10	11.5
B	2.5	8.5	11.0
C	2.5	8.5	11.0
		Total	33.5 strand/ft

Average  $33.5/3 = 11.17$  strand/ft

$$\text{Weight} = 0.153 * 3.4 * 11.17 * 91 * 620 = 327836 \text{ pounds}$$

-----



## 5.8.3 Post Tensioning in Tie Beam Bottom Flange

Maximum required post tensioning stress before losses equals 2474 psi.

$$\text{Force} = 2474 * 2 * 144 = 712500 \text{ pounds}$$

$$\text{Allowable strand stress} = 151199 \text{ psi}$$

$$\text{Reqd No. strand} = 712500 / (.153 * 151199) = 30.8 \text{ strand}$$

Adjust for 6.2% friction.

$$30.8 * 1.062 = 32.7$$

= Say 33 strand

Since bottom flange is overstressed in compression, the flange must be made larger than 2 square feet. This should reduce the stresses to a point that the 33 strand will be satisfactory.

Required weight of strand in flanges of tie beam

$$33 * 0.153 * 3.4 * 620 * 2 = 21287 \text{ pounds}$$

$$\text{Total strand weight} = 327836 + 21287 = 349122 \text{ pounds}$$

Check anchorage area in deck.

Design anchorage stress = 3000 psi.

$$\text{Maximum force} = 151199 * 11 * 0.153 = 270244 \text{ pounds/ft.}$$

$$\text{or } 270277 / (9 * 12) = 2502 \text{ psi} < 3000 \text{ psi OK}$$

No extra concrete required for anchorage. However, it is recommended that the end sections be thickened to simplify positioning post tensioning anchors.

-----  
 Check cast-in-place end sections. These sections must be cast and post tensioned after the precast units have been post tensioned. Since section to be post tensioning will cause a tensile force in the remainder of the deck prior tensioning will tend to be relieved. The cast-in-place section is 10 feet long. This will cause an increase in the strand stress of  $10/620 = 1.5\%$  if the last stressing is of the same magnitude as in the precast units. Additional post tensioning force will be required to overcome thrust and bending in the arch ribs. This additional post tensioning will be a larger percentage on shorter bridges.

### Other Considerations

It is clear that a lower strength concrete is acceptable for the deck in the study and that it would not have a large effect on the tension flanges of the tie beams.

One could interpret specification on the temperature condition to mean that the unlikelihood of all loads being maximum at the same time is low so that one may reduce the total tensile stress for CASE II by 1/1.25. If that is true, CASE I would control post tensioning and the area of strand required would be less than given above.

Transverse deck stresses were not examined. If the tie beam provides significant restraint to the floor beams, it will lead to tensile stresses in the deck and some transverse prestressing steel may be desirable.



## 6.0 Conclusions

It is the intent of the study to investigate design options which may lead to more practical tied arch bridges. Based upon this design study, it appears that the ideas suggested warrant further consideration.

The total weight of the proposed structure is only slightly more than the conventional design. The steel weight of the alternate is much less than that of the original design. The arch ribs increased from about 1.7 million pounds to about 1.85 million pounds. The arch bracing stayed the same at about 925 thousand pounds. The tie beams decreased from about 1.6 million pounds to zero. The floor system is decreased from about 2 million pounds to about 930 thousand pounds.

The 8000 psi concrete strength is higher than that commonly used in present practice. However, 8000 psi concrete is being used on the East Huntington Bridge in West Virginia with no reported problems (Ref.3). However, the analyses indicate that 6000 psi concrete would be adequate for this instance.

The use of 15 inch thick deck at the tie beams appears to be excessive. Shear lag appears to be critical only at the ends of the span. It seems reasonable to expect that a 9 inch deck with a large chamfer could be used over the entire span with the exception of the ends of the span near the arch ribs. At these locations a deck thickness of 15 inches is recommended. These portions are cast in-place so special deck units are not required. This modification would further reduce weight. The use of a composite steel plate on the bottom of the deck in these regions has been used for shear transfer in Germany (Ref.4). Such a change would further reduce structure weight.

Erection of the arch ribs by rotating them into position and splicing them has significant benefits in erection time and freedom from falsework obstructing water traffic. The erection procedure was reported for a concrete arch bridge in Germany(Ref.1). There the engineers felt that the method was economical for longer spans.

Another configuration of the deck was examined where the stiffness was less than that of the cases reported. An important relationship between deck stiffness and arch moments was evident. As the deck becomes stiffer, arch live load moments decreases. The reason for this is that the parabolic arch is designed for a uniform load. If the deck equalizes the loads, the moment in the arch will be smaller, permitting thinner arch ribs.

The normal tied arch bridge depends only on the tie beam for stiffness whereas the suggested method utilizes the entire deck stiffness. The tie beams were made 9 feet deep compared to 11 feet on the original design. This reduction in stiffness was more than balanced by the addition of the deck. A greater depth would have reduced the moment in the arch but the arch was controlled by the erection so no benefit would have resulted. The reduced depth would lead to a decrease in wind loading.

Since the deck is integral with the tie beam, lateral loads may be resisted by the deck and tie beams. This permitted the elimination of two levels of diagonal bracing required in the original design.

The use of the dead load tie cable and the post tensioned tie beams insures that the ties are not fracture critical. They further simplify construction by reducing the amount of field bolting.

The continuous deck provides a much smoother riding surface and a reduction in maintenance costs. It is most probable that an impervious wearing surface would be installed to further protect the joints. The cost of this surfacing must be considered in any economic evaluation. It appears that a reasonable amount of post tensioning steel is required.



## 7.0 Acknowledgements

This work was initiated at the request of the American Institute of Steel Construction who funded a portion of the work for which we are grateful. They also provided the design drawings for the original design from which the alternate design was derived. The interest and encouragement of AISC staff are also appreciated.

There have been fruitful discussions with several design consultants concerning this work. Particularly helpful was the firm of Arvid Grant & Associates whom we learned, toward the end of the work, had designed a bridge not dissimilar to that proposed. Unfortunately, for various reasons not related to the adequacy of the design, the structure was not built.

The figures were drawn by G. David Brierley-Green of BSDI who also reviewed the entire manuscript and made numerous contributions. Don B. VanFossen of BSDI produced the computer runs, made the computer models used and reviewed the manuscript.

## 8.0 Bibliography

1. "Arch halves fall, making pivotal link in Germany"  
Engineering News Record, June 13, 1985.
2. "Bridge fixed quickly under traffic", Engineering  
News Record, November 19, 1981.
3. "Hybrid girder in cable-stayed debut", Engineering  
Engineering News Record, June 13, 1985.
4. Roik, Karlheinz and Haesel, Jochen, "COMPOSITE  
BRIDGES IN GERMANY", Second US-Japan Joint  
Seminar on Composite and Mixed Construction,  
University Washington, Seattle. July 18-20,  
1984.
5. "Standard Specifications for Highway Bridges,  
Thirteenth Edition", American Association of  
State Highway and Transportation Officials,  
Washington, D. C., 1983.



